

The world's [**FASTEST**] ducting

800-533-5286

www.nordfab.com

ID: 030112



AIRIndustries

13 SWANSON RD
NEW BOSTON, NH 03070 603-487-1117

QUICK-FIT

Technical Manual

- Easy & fast to install
- Easy Clean-Outs
- Leak-tight laser welded seams
- Re-useable

**Cuts installation and downtime
by more than 45%**



Made in the USA

REGISTERED
ISO
9001:2008
14001:2004



QUICK-FIT

THE WORLD'S FASTEST DUCTING

TABLE OF CONTENTS

| <u>DESCRIPTION</u> | <u>PAGE</u> |
|--|--------------------|
| ADJUSTABLE NIPPLE ASSEMBLY FOR DRY APPLICATION | 41 |
| AIR VOLUME CHART | 46 |
| BLAST GATE (AUTO) | 22-23 |
| BRANCH STYLES | 15 |
| CLAMP DIAGRAM | 7 |
| CLAMP GASKET ALTERNATIVES | 8 |
| COLLAPSIBILITY & LEAKAGE | 6 |
| CONSTRUCTION METHODS | 12 |
| DIVERTER VALVE | 26 |
| DRY SYSTEM INSTALLATION | 38 |
| ELBOWS | 14 |
| ENGINEERING SPECIFICATIONS | 4-5 |
| EXPLOSION ISOLATION FLAP | 30-31 |
| FITTINGS | 10 |
| FLANGED DUCT SPECIFICATIONS | 11 |
| FLASHING (WALL & ROOF) | 40 |
| FLEX HOSE STYLES | 19 |
| FUME ARMS | 28 |
| GAUGE DATA SHEET & ORDERING INFORMATION | 9 |
| GRIPPLE HANGER SYSTEM | 35 |
| INLINE SILENCER | 33 |
| INSTALLING THE LEAK-FREE GASKET | 43 |
| INSTALLING THE LEAK-FREE O-RING | 44 |
| INSTALLING AN IN-CUT OR TAP-IN | 32 |
| JET CAP | 29 |
| MIST RECYCLER | 34 |
| NO LOSS STACKHEAD | 29 |
| REDUCER STYLES | 18 |
| RIGID & ULTRA FLEX METAL HOSE | 21 |
| RUBBER FLEX HOSE | 20 |
| SD BLAST GATE AUTO | 24-25 |
| SD DIVERTER VALVE | 27 |
| SIZING A SYSTEM & USING THE CHART | 45 |
| SIZING BRANCHES | 16 |
| SIZING ELBOWS & SPECIAL COMPONENTS | 13 |
| SLIDING ACCESS PANEL | 34 |
| STRUCTURAL INTEGRITY & LEAKAGE CLASS | 3 |
| TAKE-OFF SHEET | 47 |
| THINGS TO BE AWARE OF WHEN ORDERING | 9 |
| TRANSITION STYLES | 17 |
| TYPICAL CEILING HANGING METHOD | 37 |
| WALL MOUNTING BRACE | 36 |
| WET APPLICATION MATERIALS | 42 |
| WET SYSTEM INSTALLATION | 39 |

**QUICK-FIT****THE WORLD'S FASTEST DUCTING**

NORDFAB

December 16, 2011

To whom it may concern

Reference: Structural integrity of "QF" Piping System

The Nordfab Laser "Quick-Fit" Piping System has been used in many different industrial applications, and under various negative static pressures.

The typical design range we see in our applications range from -2" wg to -28" wg, however we have some systems operating at vacuums of -32" wg to -42" wg under normal operating parameters.

Please take into account that our pipe comes in 5' lengths with a rolled lip on each end, thus providing reinforcement every 5', which presents a sound structural design that should be stronger than any pipe in its class according to SMACNA guidelines and regulations.

Sincerely,
Tom Ballus
President

STRUCTURAL INTEGRITY

All fit together ducting systems allow for some degree of leakage. "Q-F" ducting is no exception and is not sold as an airtight system. In addition to our standard Nitrile gasket, NORDFAB offers special clamp gasket material for high heat, food applications, etc. However, the "Q-F" system is sold as a quick way of installing and modifying duct-work while at the same time retaining the usability of each component. In short, "Q-F" is meant to be able to be taken apart, re-assembled, stored or moved. Completely eliminating the possibility for leakage jeopardizes the inherent benefits of the duct.

While NORDFAB is currently unaware of any method of evaluating dust collection piping alone, the following data is presented using the criteria for all duct, including HVAC. This data is presented only for the purpose of indicating acceptability of the "Q-F" in dust/fume removal in a negative pressure situation and should not be confused with the ducting that uses tape or gaskets as sealant in the positive conveyance of air.

LEAKAGE CLASS DETERMINED IN ACCORDANCE WITH SMACNA

| Duct Size | Avg. leakage per 100 ft. | | SMACNA CLASS |
|-----------|--------------------------|---------|--------------|
| | 5" SP | 10" SP | |
| 4" 6" | 5 CFM | 6 CFM | 3 |
| 7" 10" | 2.5 CFM | 3.5 CFM | 3 |
| 11" 24" | 2 CFM | 4 CFM | 3 |



QUICK-FIT

THE WORLD'S FASTEST DUCTING

GENERAL ENGINEERING SPECIFICATION FOR NORDFAB QUICK FIT DUCTING

MANUFACTURING PROFILE:

Nordfab Quick-Fit Ducting is manufactured in Thomasville, NC and Sparks, NV. Nordfab duct is a clamp-together design using a rolled edge design with a single lever clamp. The ducting and clamps are made of similar materials. During manufacturing the duct material sheet blanks, which are five feet long, are rolled and fused together with a laser weld process along the longitudinal seam. Each pipe is checked with a light apparatus for any welding flaws or gaps. The rolled edge is then die-formed after inspection by rolling each end of the pipe simultaneously. The laser weld prevents any gaps in the rolled edge from forming. This rolled end is used for clamping components together as well as offering reinforcement every five feet. All clamps contain a standard gasket made of Nitrile which is suitable for most applications, including oil mist, as long as high temperatures are not an issue. An ePTFE gasket option is available for food grade and high temp applications. Nordfab Quick-Fit Ducting is available in 1" increments sized 3" to 24" diameter.

Engineering Specification:

1. Ducting shall consist of the following:
 - a. Galvanized: ASTM A527 with a G90 rating
 - i. Temp rating is 500° F with no breakdown of zinc - Zinc melting point is 740° F
 - b. 304SS: Finish meets ASTM A240
 - i. Temp rating is 1,100° F
 - c. 316SS: Finish meets ASTM A240
 - i. Temp rating is 1,100° F

2. Ducting manufacturing techniques:
 - a. Diameters 3" - 24" pipe, adjustable nipples, and collars attached to other components will have one or both ends die formed-rolled to provide a uniform edge around the circumference of the rolled end. The pipe and adjustable nipples shall have the longitudinal seam laser welded to allow for a tighter slip joint and reduce system pressure losses. All laser welded seams will undergo a light test to ensure there are no voids or imperfections in the system. Pipe lengths using laser welded seams will not exceed a nominal 60" length. The rolled edges provide structural support at 5' intervals or less and can be interpreted as a stiffener where SMACNA specifications are required. An adjustable nipple is used for adjustment during the install process. Pipe is cut to appropriate length and the adjustable nipple secures the pipe for install.

 - b. Pipe and other components larger than 24" shall utilize either an angle flange or flat flange attached loosely and retained in place using a 3/8" vanstone lip. The pipe shall have a compressed-interlocking lap form seam and not exceed 78" in length. The angle or flat flanges provide structural support at 6'-6" intervals or less and are considered as stiffeners where SMACNA specifications are required.

 - c. There will be times when certain components will be air direction sensitive. These components will have an arrow sticker attached showing the proper flow direction.

 - d. All ducting and its components shall have been tested to 80" WG using the following gauged reference:
 - i. 3" will use 18ga material thickness
 - ii. 4" through 12" will use 22ga material thickness
 - iii. 13" through 29" will use 20ga material thickness
 - iv. 30" and above will use 18ga material thickness

Engineering Specification (cont.):

**QUICK-FIT****THE WORLD'S FASTEST DUCTING**

3. Clamping rolled edged duct:
 - a. Clamps shall be constructed with an over-center, spring-lever action for quick connecting of two pieces of ducting. A retaining pin shall be inserted in the handle and an eyelet on the clamp as a safety feature to ensure the handle does not prematurely come undone.
 - b. When closing the clamp, the internal seal shall be compressed in such a manner as to cover both rolled beads for optimum sealing capacity in a full 360° pattern.
4. Optional caulking and other materials governing system temperature ratings if applicable:
 - a. Approved caulk is 3M Scotch Seal Metal Sealant 2084 or equivalent for system temperatures of 250°F or lower
 - b. Optional approved caulk is 3M DP460 two part epoxy or equivalent for system temperatures of 375°F or lower
 - c. Optional approved caulk is RTV 100 Series, Mil-A-46106B Compliance, UL/FDA/NSF or equivalent for system temperatures of 400°F or lower
 - d. Optional approved caulk is Permatex RTV Silicone Rubber Adhesive High Temperature Caulk (red in color) or equivalent for system temperatures of 500°F or lower
 - e. Sealing gaskets
 - i. Buna-N, 70 Duro-Meter hardness with a temperature rating of 250°F maximum and is black in color, used with the adjustable nipple
 - ii. Silicon rubber, ZZ-R-765 Class 2A and 2B grade 770 AMS-3304E and 3304F and 3303G, FDA approved and is red in color, used with the adjustable nipple
 - iii. Molded gaskets shall meet the material classification of ASTM D-2000 M2BG510 A24 B34 EO14 EO34 EF11 EF21 and used in systems where the temperature rating is 225°F or less and are black in color. This component shall be made using conductive materials for conductivity.
 - iv. Sponge o-ring shall meet the material classification of either ASTM D-1056-68 – SBE43 or ASTM D1056-85, 91, 98 – 2B3
 - v. Clamp seals shall be made of either of the following:
 1. Nitrile to meet or exceed ASTM D 1056 standards with a temperature rating not to exceed 158°F constant temperature (or intermittent temperature of 194°F).
 2. ePTFE to meet or exceed FDA /pharmaceutical standards for food usage and not be degraded by any common chemicals in the 0-14 PH range. Temperature rating shall not exceed 600°F.
5. Conductivity:
 - a. Metal-to-metal contact shall be obtained at all joint connections. Die-formed rolled edges are uniform in shape which provides the most consistent contact. The ears of the clamp contact with the rolled edges and provide maximum conductivity. Conductivity shall be adhered to per NFPA 77 paragraph 8.4.1.1; states all parts of the continuous metal piping system should have a resistance level that does not exceed 10 ohms. Testing is the responsibility of the owner.



QUICK-FIT

THE WORLD'S FASTEST DUCTING

COLLAPSIBILITY & LEAKAGE DATA

COLLAPSIBILITY STRENGTH OF "Q-F" PIPING

Each size of piping has been tested for strength against collapsing. The piping was exposed to constant positive pressure and constant vacuum. Each pipe was exposed to a maximum capacity of the test equipment of 80" WG of vacuum and positive pressure. None of the pipe showed any form of deformation during the test. Please take into account that our pipe comes in 5' lengths with a rolled lip on each end, thus providing reinforcement every 5', which presents a sound structural design that should be stronger than any pipe in its class. Pipe and fittings must be installed in accordance with NORDFAB's standard specifications and standard accepted practices.

LEAKAGE RATE

All fit together ducting systems allow for some degree of leakage where they are joined. "Q-F" ducting is no exception and is not sold as an airtight system. However, versus the other ducting typically used in fit together systems, Nordfab's Quick-Fit (Q-F) ducting has fully welded, leak-tight laser welded seams. Spiral and other ducting with lock form seams are NOT fully welded at the seams and can be expected to have higher leakage rates than "Q-F".

In addition to our standard Nitrile gasket, NORDFAB also offers special clamp gasket material for high heat, food applications, etc. Further, the applying of sealants to the individual rolled ends can enhance the tightness of the system. However, the "Q-F" system is sold as a quick way of installing and modifying duct-work while at the same time retaining the usability of each component. In short, "Q-F" is meant to be able to be taken apart, re-assembled, stored, or moved. Completely eliminating the possibility for leakage jeopardizes the inherent benefits of the duct. Standard "Q-F" is designed to provide tight sealing and efficient airflow under negative pressures. To that end, we are providing the following information for piping situations where fan sizing is of extreme importance. The following data was obtained using standard components and was performed in accordance with the SMACNA, "HVAC AIR DUCT LEAKAGE TEST MANUAL". The information gives the leakage rate per joint of duct at various pressures. To utilize the chart, count the number of clamps, (this equals the number of pieces), per size and multiply by the number given beside the corresponding diameter and under the applicable pressure. These numbers assume that the product is correctly installed; free of dents in the joining ends and that the gasket is in place. Special gasket material and sealants will increase the sealing capabilities.

LEAKAGE RATE IN CFM PER QF JOINT

| Dia Inches | 3 WG | 5 WG | 7.5 WG | 10 WG | 15 WG | 20 WG | 25 WG | 30 WG |
|------------|------|------|--------|-------|-------|-------|-------|-------|
| 4 | 0.20 | 0.25 | 0.30 | 0.30 | 0.35 | 0.50 | 0.60 | 0.80 |
| 5 | 0.20 | 0.25 | 0.30 | 0.30 | 0.35 | 0.50 | 0.60 | 0.80 |
| 6 | 0.20 | 0.25 | 0.30 | 0.30 | 0.35 | 0.50 | 0.60 | 0.80 |
| 7 | 0.20 | 0.25 | 0.30 | 0.30 | 0.35 | 0.50 | 0.60 | 0.80 |
| 8 | 0.20 | 0.25 | 0.30 | 0.30 | 0.35 | 0.50 | 0.60 | 0.80 |
| 9 | 0.20 | 0.25 | 0.30 | 0.30 | 0.35 | 0.50 | 0.60 | 0.80 |
| 10 | 0.20 | 0.25 | 0.30 | 0.30 | 0.35 | 0.50 | 0.60 | 0.80 |
| 12 | 0.30 | 0.30 | 0.40 | 0.40 | 0.40 | 0.60 | 0.70 | 0.90 |
| 14 | 0.30 | 0.30 | 0.50 | 0.70 | 0.80 | 0.80 | 0.90 | 1.10 |
| 16 | 0.30 | 0.40 | 0.60 | 0.70 | 1.00 | 1.10 | 1.20 | 1.40 |
| 18 | 0.40 | 0.40 | 0.70 | 0.80 | 1.10 | 1.30 | 1.50 | 1.70 |
| 20 | 0.40 | 0.60 | 0.80 | 0.90 | 1.20 | 1.50 | 1.70 | 2.00 |
| 22 | 0.40 | 0.60 | 0.80 | 1.10 | 1.40 | 1.50 | 2.00 | 2.20 |



QUICK-FIT

THE WORLD'S FASTEST DUCTING

Q-F CLAMP

Stainless Style

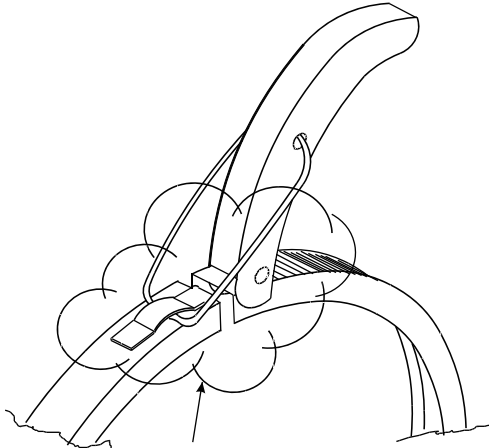

See Detail on Right

Position # 1

Seal Will Be Installed And Folded Over At the Factory. It Will Release Easily Due To The Pressure Sensitive Backing.

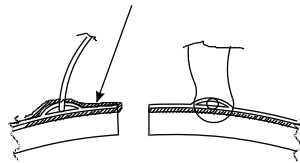

Position # 2

While Clamping Down, Slowly Tuck Extra Seal Underneath The Opposing Side Of Clamp.

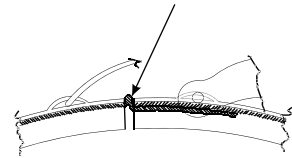

Die Formed Rolled Edge



"QF" Clamp

Nitrile Gasket

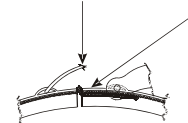

Galvanized Style

Quick-Seal Clamps

Since 1986, the Nordfab Quick-Fit clamp has been the world's best selling and best sealing duct clamp. It has set the standard for use in industrial dust, mist, smoke and fume collection. Many have tried to imitate it, but we've found none who have ever matched, or improved upon, its tight, leak-resistant seal.

Until now...

The New Nordfab Quick-Seal clamp uses our new revolutionary "overlap" design. This ensures the tightest seal possible.

Additionally, we have lengthened the handle for the Quick-Seal clamp and made it stronger, giving you more leverage to clamp down for super tight seals.

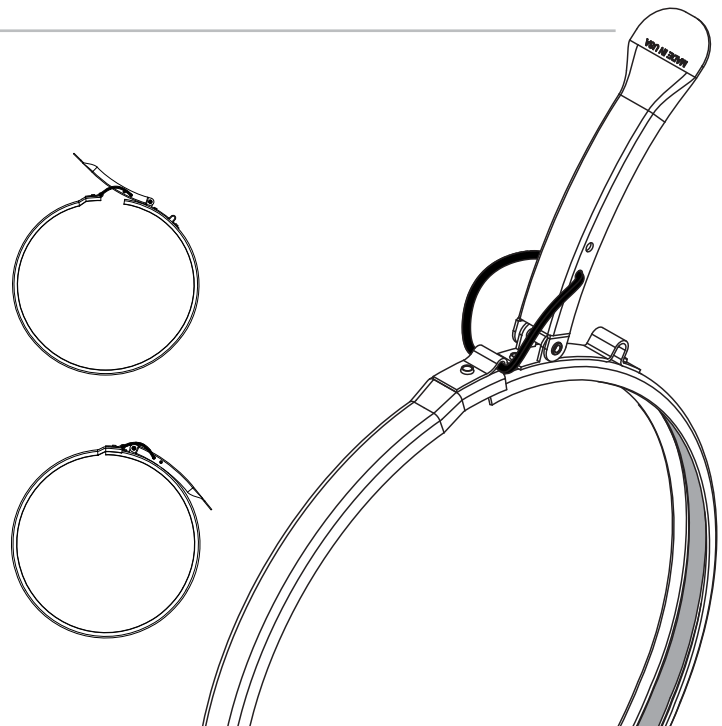



QUICK-FIT

THE WORLD'S FASTEST DUCTING

“Q-F” CLAMP GASKETING ALTERNATIVES

1. NITRILE GASKET-STANDARD

- Service temperature: -104° F to +158 ° F with an intermittent max temp of +194° F.
- Standard seal installed in clamp
- The standard specifications meet ASTM D 1056.
- 3/8” Gasket for 4”,5”,6”
- 1/2 ” Gasket for 7” - 11”
- 21/32” Gasket for 12” - 24”

2. ePTFE GASKET

- Service temperature -450 DEG F. to 600 DEG F
- FDA suitable for use in food and pharmaceutical industries
- Not degraded by any common chemicals [0-14 PH range]
- Non-contaminating and non-aging
- 3/8” gasket for 4”,5”,6”
- 1/2” gasket for 7” and larger
- 21/32” Gasket for 12” - 24”

O-RINGS

Temperature Rating:

250° F - O-ring Black: Included with adjustable nipples as standard

500° F - O-ring Red: Optional for higher temperatures and FDA approval -
Order separately and replace on site

Material Specifications:

O-ring Black: Buna-N, 70 Duro-Meter hardness

O-ring Red: Silicon rubber, ZZ-R-765 Class 2A and 2B grade 70 AMS-3304E and 3304F and 3303G, FDA approved ordered separately and replace on site.



QUICK-FIT

THE WORLD'S FASTEST DUCTING

GAUGE DATA SHEET & ORDERING INFORMATION

QUICK-FIT GAUGE DATA SHEET

| DIA | PIPE | | PIPE STD GAUGE | NIPPLE | | NIPPLE STD GAUGE | MAX GALV GA | | MAX SS GA UPGRADE |
|-----|-------|-------|----------------|--------|-------|------------------|-------------|--------|-------------------|
| | ID | OD | | ID | OD | | PIPE | NIPPLE | |
| 3" | 2.90 | 3.00 | 18 | 3.07 | 3.15 | 22 | N/A | N/A | 20 |
| 4" | 3.86 | 3.93 | 22 | 3.96 | 4.03 | 22 | 18 | 18 | 20 |
| 5" | 4.87 | 4.94 | 22 | 4.96 | 5.03 | 22 | 18 | 18 | 20 |
| 6" | 5.89 | 5.96 | 22 | 5.99 | 6.06 | 22 | 18 | 18 | 20 |
| 7" | 6.89 | 6.96 | 22 | 7.00 | 7.07 | 22 | 18 | 18 | 20 |
| 8" | 7.88 | 7.95 | 22 | 8.00 | 8.06 | 22 | 16 | 16 | 20 |
| 9" | 8.88 | 8.95 | 22 | 9.00 | 9.06 | 22 | 16 | 16 | 20 |
| 10" | 9.89 | 9.95 | 22 | 10.00 | 10.07 | 22 | 16 | 16 | 20 |
| 11" | 10.88 | 10.94 | 22 | 11.12 | 11.19 | 22 | 16 | 16 | 20 |
| 12" | 11.97 | 12.04 | 22 | 12.11 | 12.17 | 22 | 16 | 16 | 20 |
| 13" | 12.97 | 13.05 | 20 | 13.12 | 13.20 | 20 | 16 | 16 | 20 |
| 14" | 13.96 | 14.04 | 20 | 14.10 | 14.18 | 20 | 16 | 16 | 20 |
| 15" | 14.97 | 15.04 | 20 | 15.12 | 15.20 | 20 | 16 | 16 | 20 |
| 16" | 15.97 | 16.04 | 20 | 16.10 | 16.18 | 20 | 16 | 16 | 20 |
| 17" | 16.97 | 17.05 | 20 | 17.07 | 17.15 | 20 | 16 | 16 | 20 |
| 18" | 17.96 | 18.04 | 20 | 18.10 | 18.18 | 20 | 16 | 16 | 20 |
| 19" | 18.91 | 19.00 | 20 | 19.07 | 19.15 | 20 | 16 | 16 | 20 |
| 20" | 19.96 | 20.04 | 20 | 20.10 | 20.18 | 20 | 16 | 16 | 20 |
| 21" | 20.92 | 21.01 | 20 | 21.07 | 21.15 | 20 | 16 | 16 | 20 |
| 22" | 21.97 | 22.05 | 20 | 22.11 | 22.19 | 20 | 16 | 16 | 20 |
| 23" | 22.91 | 23.00 | 20 | 23.07 | 23.15 | 20 | 16 | 16 | 20 |
| 24" | 23.94 | 24.02 | 20 | 24.06 | 24.14 | 20 | 16 | 16 | 20 |

THINGS TO BE AWARE OF WHEN ORDERING "Q-F"

- Order one clamp per "Q-F" component.
 - One duct = one clamp
 - Two elbows = two clamps
- Specify dimensional information to speed up process:
 - Transitions A,B,D,L,X, Y and flange style
 - Branches A x B x C, or A x B x D, or A x B x C x D
 - Tap-In or In-cuts A, B
 - Reducer All diameters and end style

THERE IS NO SUCH THING AS TOO MUCH INFORMATION !

- Look for 60 degree elbows to compliment standard branch orders with 30° tap. This is typical application since the two components will create a perpendicular run to the trunk line.
- Ask for flange styles, hole patterns, ID, OD, when applicable. Typical components requiring flanges will be parts that connect to filters, fans, or other types of equipment.



QUICK-FIT

THE WORLD'S FASTEST DUCTING

FITTINGS

- A) Branch fittings are produced to have a concentric design, as they taper to a specific dimension. Joints are lapped, spot welded, cleaned, and painted with KRYLON Industrial Tough Coat, Acrylic Enamel #1760 Aluminum. Seams are sealed with 3M Scotch-Seal (R) 2084 grey sealant.
- B) Fitting gauges vary from 22 to 16 gauge depending on the configuration of the branch or fitting. Gauge can generally be determined by using the corresponding QF Pipe diameter gauge. If exact gauge is required, contact factory for more information.
- C) All standard branch fittings are produced on a 30 degree angle, however other angles (7.5° - 90°) are available upon request.
- D) As a normal practice, internal welds are not cleaned or painted. Cleaning or painting the inside is an option based on the customer's application and is done only at the customer's request with an **upcharge**.

EXAMPLES OF VARIOUS FITTINGS AVAILABLE

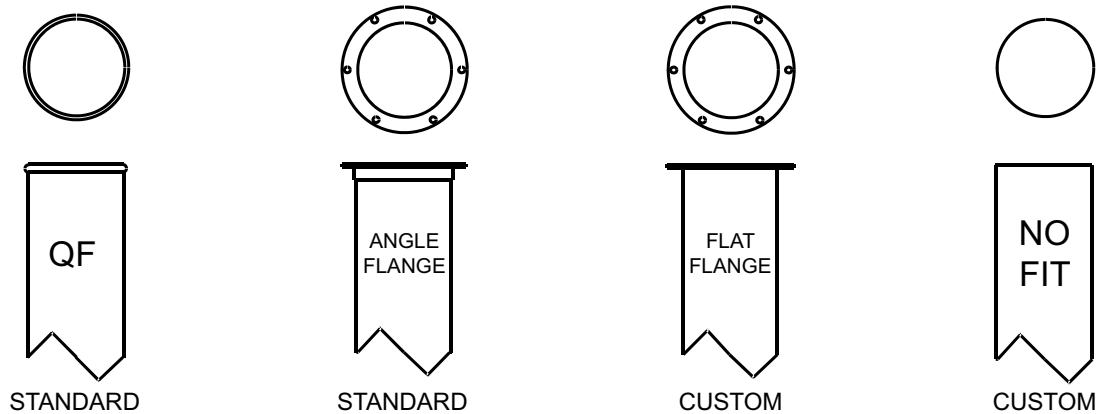

INFORMATION NEEDED TO ORDER A CUSTOM FLANGE

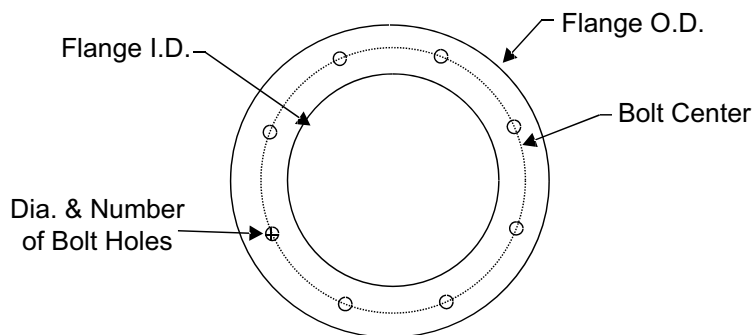

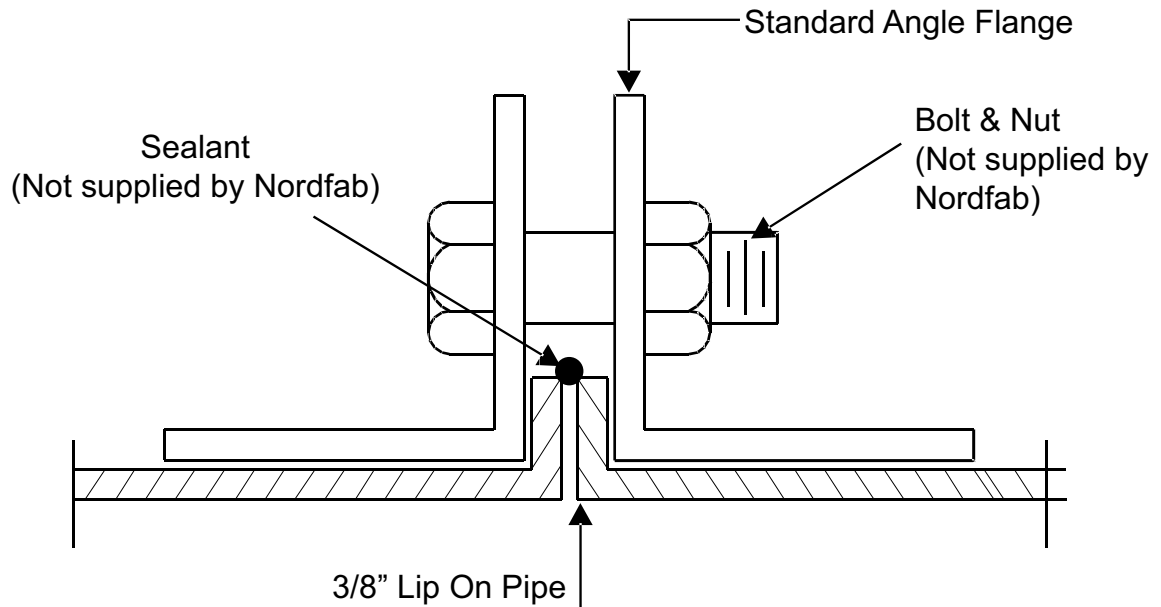
**QUICK-FIT****THE WORLD'S FASTEST DUCTING****FLANGE DUCT SPECIFICATION**

- A) "Flanged" = Material sheet blanks are 78.75" lg. and rolled with a longitudinal lock formed seam. An angle flange made from angle bar stock rolled on edge is placed on the end of the duct using a Van Stone Lip Connection as illustrated above. (See Nordfab Catalog for sizes)
- B) Refer to your local guidelines and codes for how ducting should be supported
- C) Duct diameters for FLANGE DUCT as follows:
3" through 40" available in 1" increments



QUICK-FIT

THE WORLD'S FASTEST DUCTING

EXAMPLES OF CONSTRUCTION METHODS

1. LONGITUDINAL LASER WELD SEAM FOR "Q-F" PIPE

* Applies to all straight duct up to 24", adapters, nipples, collars, and most elbows.
All Reno made elbows are supplied with standard seam - see figure 5 below

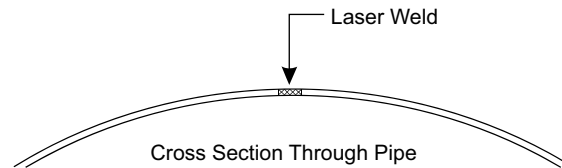

2. STANDING SEAM

* Applied to segmented elbows, offsets and end caps.

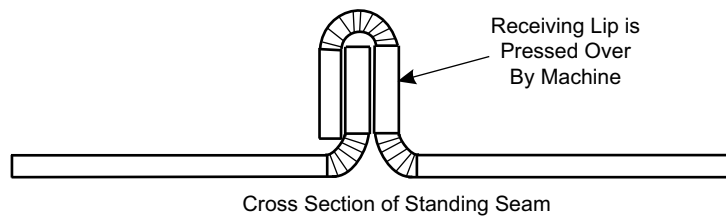

3. LONGITUDINAL LOCK FORM SEAM ON FLANGE PIPE

* Applies to all straight duct flanged lengths.

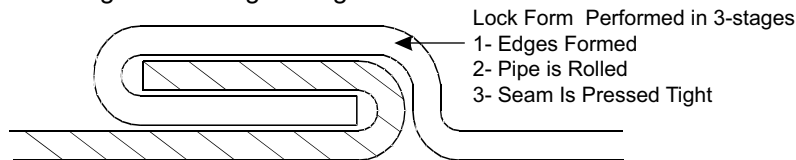

4. OVERLAPPED, SPOT WELDED SEAM CONSTRUCTION AND QF COLLAR CONNECTION

* Applies to all branches, reducers, in-cuts, etc.

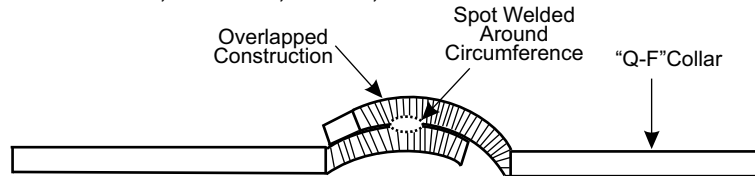

5. STANDARD SEAM JOINING METHOD ON HOODS, BOXES, TRANSITIONS, AND SPECIALTY ITEMS

* Lapped, spot welded, and caulked.

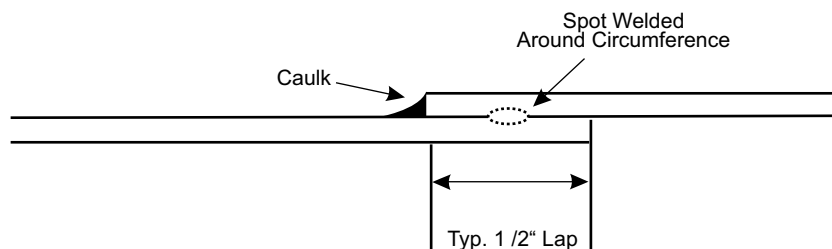



QUICK-FIT

THE WORLD'S FASTEST DUCTING

SIZING ELBOWS & SPECIAL COMPONENTS

SIZING ELBOWS

The catalog lists the standard sizes and the standard gauges; however, NORDFAB also makes elbows in long radius and in heavier gauges. The elbows can be made in segments or can be made smooth walled. Pricing for the various sizes and gauges should be obtained by calling NORDFAB.

SPECIAL COMPONENTS

As with the elbows, NORDFAB is able to provide special hoods or special designed pieces for almost any dust collection application. To obtain help in design or pricing, call NORDFAB.

ADAPTING TO EXISTING SYSTEMS

There will be instances where the customer will desire to apply "QF" duct to an existing ducting system; NORDFAB makes adapters for this purpose. We can provide these in flange to "QF" or through simply supplying "raw to QF" adapters that can be attached to the end of existing spiral duct so that "QF" can be coupled to the duct.

CAULK SELECTION AVAILABLE ON ALL COMPONENTS

Temperature Rating:

250° F - Standard Caulk - 3M Scotch Seal Metal Sealant 2084 - Standard (contact your dealer for pricing and other options)

250° F - Optional Oil Mist - 3M 2084 Scotch Seal Metal Sealant

375° F - Optional Epoxy Caulk - 3M DP460

400° F - Optional RTV 100 Series, Mil-A-46106B Compliance, UL/FDA/NSF

500° F - Optional Permatex RTV Silicone Rubber Adhesive High Temperature Caulk - Red in color - 26C

Material Specifications:

Galvanized: ASTM A527 with a G-90 rating

500° F - Galvanized with little or no breakdown of zinc - zinc melting point is 740° F

500° F - Optional galvanized and seams solid welded

304SS: Finish meets ASTM A240

1100° F - 304SS bluing may occur at temperatures of 800° F

1100° F - Optional 304SS and seams solid welded

316SS: Finish meets ASTM A240

Note: For temperatures 250° F. to 500° F. please request RTV High temp silicone caulk on components. Contact NORDFAB for adder.

Galvanized: Ducting will accommodate systems 0 to 500° F. with little or no breakdown of the zinc coating - zinc melting point is 740° F.

304SS: Ducting will accommodate systems 500 to 1100° F with no problems. With temps above 800° F, a small amount of "bluing" may occur.

PAINTING GALVANIZED COMPONENTS

Step 1. Wash down all components with an industrial de-greaser, insuring that no oils or residues are left behind.

Step 2. Apply an epoxy primer in a light coating.

Step 3. For a final coat, apply an acrylic water base paint. (Example: Glidden Lifemaster)



QUICK-FIT

THE WORLD'S FASTEST DUCTING

ELBOWS

- A) Standard elbows will have a centerline radii of 1 x dia & 1.5 x dia as specified in catalog .Longer radius elbows are available upon request.
- B) Standard elbows 3" to 7" are pressed formed, 8" and larger are gored construction with a lock form standing seam every 15 degrees. Gore type elbows are produced as follows:

| <u>ANGLE IN DEGREES</u> | <u>NUMBER OF GORES</u> |
|-------------------------|---------------------------------|
| 15° | (2) 7.5° + 2 tangents |
| 30° | (1) 15° + (2) 7.5° + 2 tangents |
| 45° | (2) 15° + (2) 7.5° + 2 tangents |
| 60° | (3) 15° + (2) 7.5° + 2 tangents |
| 90° | (5) 15° + (2) 7.5° + 2 tangents |

ELBOW STANDARD AND UPGRADES FOR QF AND ANGLE FLANGE

NOTE: TUBED ELBOWS ARE AVAILABLE @ 14 GA EXCEPT 3-4" GAL @ 16GA

| ELBOW DIAMETER | GALV STD GAUGE | SS STD GAUGE | ONE GAUGE UPGRADE | MAX HEAVY WALL STYLE ELBOW |
|----------------|----------------|--------------|-------------------|----------------------------|
| 3" | 24 | 14 TUBED | N/A | N/A |
| 4" | 24 | 14 TUBED | N/A | N/A |
| 5" | 24 | 14 TUBED | N/A | N/A |
| 6" | 24 | 14 TUBED | N/A | N/A |
| 7" | 24 | 22 | 18 | 16 |
| 8" | 22 | 22 | 18 | 16 |
| 9" | 22 | 22 | 18 | 16 |
| 10" | 22 | 22 | 18 | 16 |
| 11" | 22 | 22 | 18 | 16 |
| 12" | 22 | 22 | 18 | 16 |
| 13" | 20 | 20 | 18 | 16 |
| 14" | 20 | 20 | 18 | 16 |
| 15" | 20 | 20 | 18 | 16 |
| 16" | 20 | 20 | 18 | 16 |
| 17" | 20 | 20 | 18 | 16 |
| 18" | 20 | 20 | 18 | 16 |
| 19" | 20 | 20 | 18 | 16 |
| 20" | 20 | 20 | 18 | 16 |
| 21" | 20 | 20 | 18 | 16 |
| 22" | 20 | 20 | 18 | 16 |
| 23" | 20 | 20 | 18 | 16 |
| 24" | 20 | 20 | 18 | 16 |
| 26" | 18 | 18 | 16 | 16 |
| 28" | 18 | 18 | 16 | 16 |
| 30" | 18 | 18 | 16 | 16 |
| 32" | 18 | 18 | 16 | 16 |
| 34" | 16 | 16 | 16 | 16 |
| 36" | 16 | 16 | 16 | 16 |
| 38" | 16 | 16 | 16 | 16 |
| 40" | 16 | 16 | 16 | 16 |

4" GALV. ELBOW CLR EXAMPLE

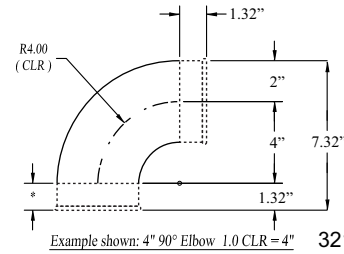

3210-0490-104000

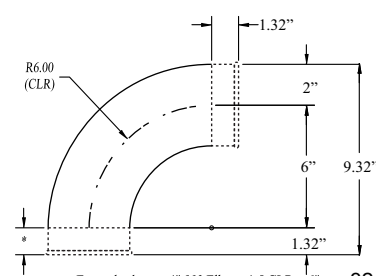

3210-0490-106000

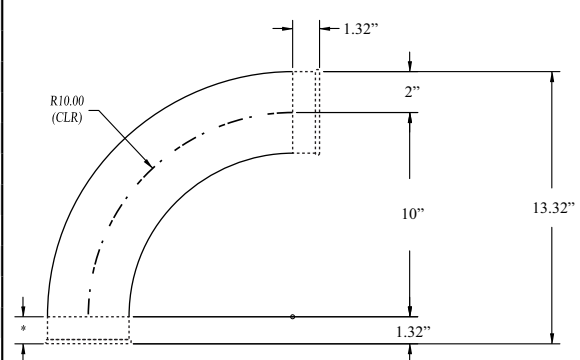

3210-0490-110000

NOTE: Overall height calculation only works with 90° elbows.



QUICK-FIT

THE WORLD'S FASTEST DUCTING

BRANCH STYLES

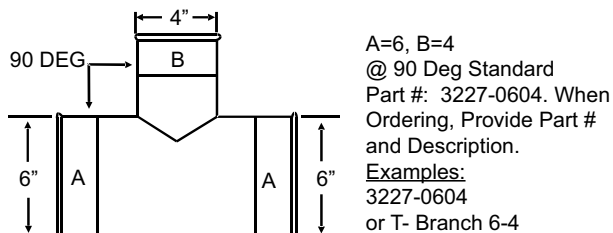
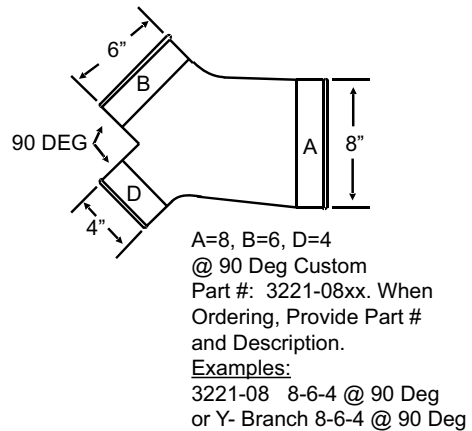
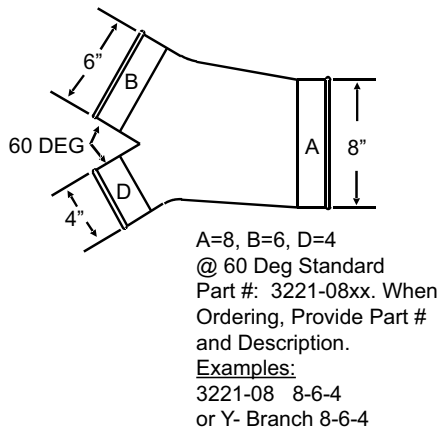
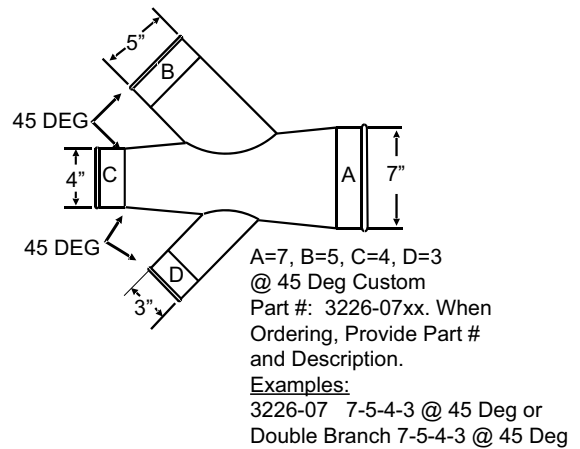
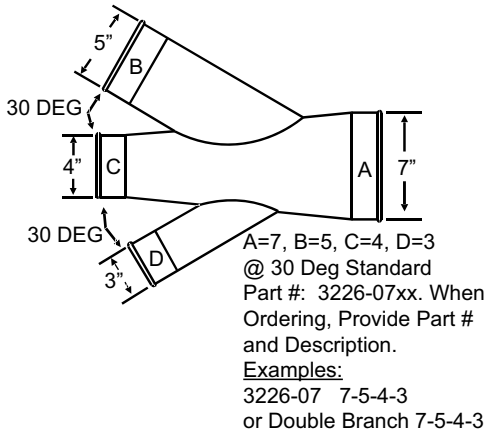
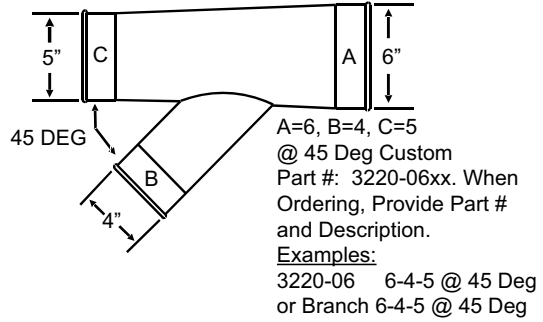
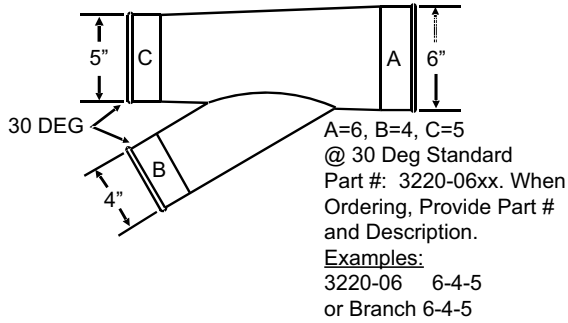



QUICK-FIT

THE WORLD'S FASTEST DUCTING

SIZING BRANCHES

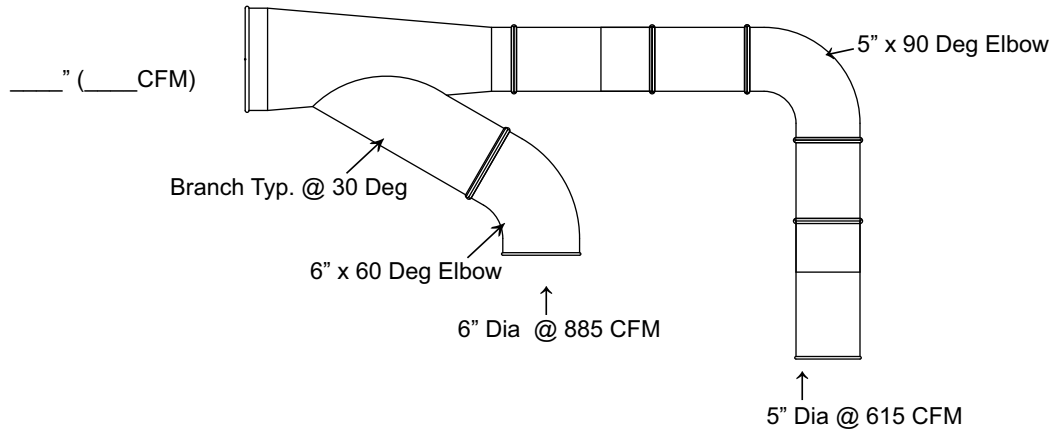

EXAMPLE: Always work from your machines back toward the filter. Suppose that you have a 5" drop that rises and runs back to join with a 6" drop as sketched above. What size branch will you need?

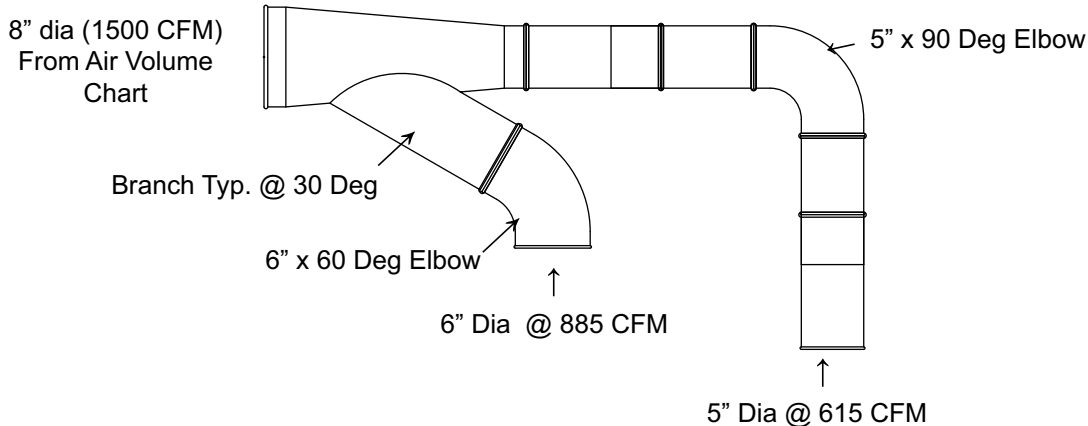

The 5" pipe carries 615 CFM at 4500 FPM, (See Chart). The 6" pipe will need 885 CFM at the same velocity (See Chart). Added together you have a total of (615 + 885) 1500 CFM coming together. Looking again at the chart under 4500 FPM, you find that 1500 CFM is not listed, but falls very close to the 1570 CFM listed for an 8" pipe. This indicates that the 5" joined to the 6" will require an 8" pipe to carry all of the material at the right velocity. The branch, therefore, will be 8" on the downstream end reducing down to a 5" with a 6" branching off of it. That is listed as a 8-6-5 branch.



TRANSITION STYLES

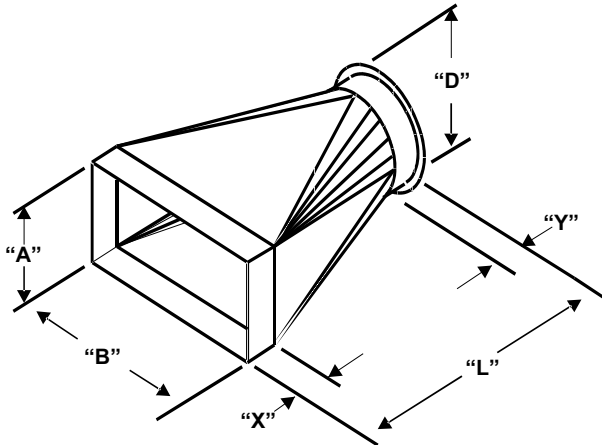

STYLE #1

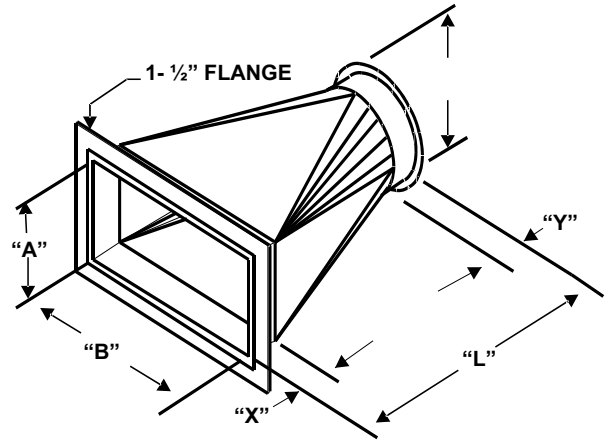

STYLE #2

Built to your specifications. Please list all required dimensions and details.

- Specify Rectangle End: Angle Flange Flat Flange Raw End I.D. Raw End O.D.
- Flange Type: Angle Flange Flat Flange Sheet Metal
- Specify Round End: QF Angle Flange Flat Flange Hose Conn.
- Raw I.D. Or O.D.

NOTE: If no hole pattern is supplied for flanges, they will be supplied "Blank" to be field drilled.
 "L" = to the greater of B or D NOTE: Minimum L for Sq to Rd is B x 0.75

| Item # | Qty. | "D" | "A" | "B" | "X" Std 2" | "Y" Std 2" | "L" | Gauge | Flange Material | Flg Dwg | Special Notes |
|--------|------|-----|-----|-----|------------|------------|-----|-------|-----------------|---------|---------------|
| | | | | | | | | | | | |
| | | | | | | | | | | | |
| | | | | | | | | | | | |
| | | | | | | | | | | | |
| | | | | | | | | | | | |



REDUCER STYLES

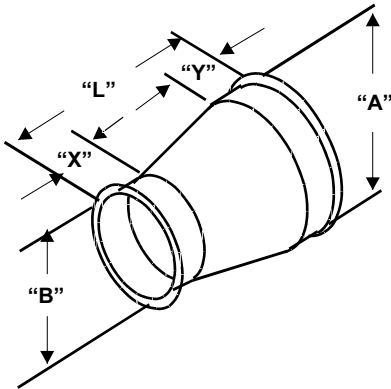

"Q-F STYLE"

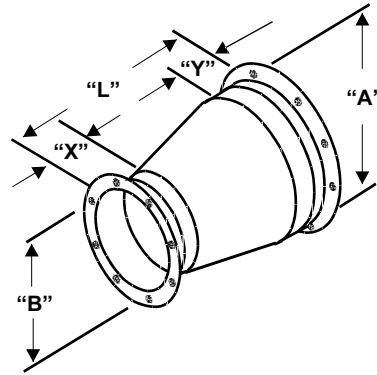

"FLANGED STYLE"

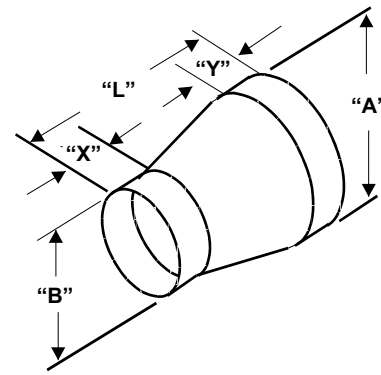

"RAW END STYLE"

A) Reducers are produced by the following formula:

"QF" LENGTH = (A-B) + 6" [7" MIN]
 "FL" LENGTH = (A-B) + 8" [9" MIN]

B) Standard material gauges as follows: (Heavier gauges available contact NORDFAB)

| DIA. | GALV. GAUGE | SS GAUGE |
|-----------|-------------|-----------|
| 4" - 12" | <u>22</u> | <u>22</u> |
| 14" - 22" | <u>20</u> | <u>20</u> |

NOTE: Any combination of the above style are available upon request. Please specify all the required dimensions and all reducer end configurations (Raw ID, Raw OD Style, QF Style, Flange Style, Etc.).

| Item# | Qty | "A" | Style "Q-F" "Flange" "Raw" | "B" | Style "Q-F" "Flange" "Raw" | "L" (A-B+6) | "X" STD-2" | "Y" STD-2" | Part Gauge | Flange Material | Fig Dwg | Special Notes |
|-------|-----|-----|-------------------------------------|-----|-------------------------------------|----------------|---------------|---------------|------------|-----------------|---------|---------------|
| | | | | | | | | | | | | |
| | | | | | | | | | | | | |
| | | | | | | | | | | | | |
| | | | | | | | | | | | | |
| | | | | | | | | | | | | |
| | | | | | | | | | | | | |



QUICK-FIT

THE WORLD'S FASTEST DUCTING

FLEX HOSE STYLES

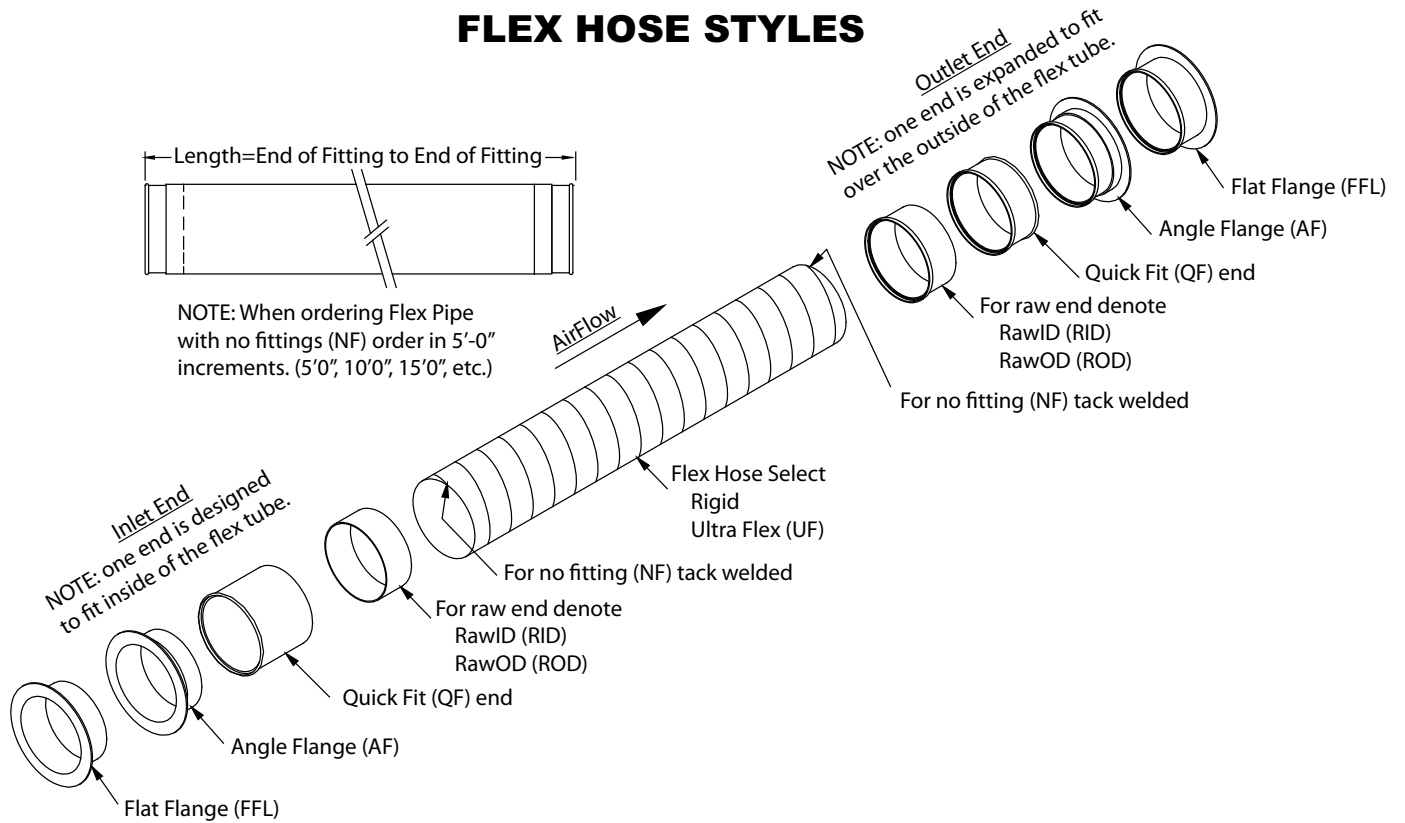

NOTES:

1. If no hole pattern is supplied for flanges, you will receive blank flanges (flanges without holes).
2. Any combination of the above style are available upon request. Please specify the inlet diameter, flex hose diameter, and outlet diameter.
3. Note the length is based on the flex hose being stretched out before cutting (not compressed).
4. Special Notes: SP=Spot Weld (Std), ST=Stitch Weld, SO=Solid Weld, BY=Buff Yes, BN=Buff No (Std), note other requirements.
5. Rigid and Ultra Flex hose is produced in 5' lengths in diameters 7" and above.

| Item # | Inlet Dia. | Inlet End Style (QF, NF, AF, FFL, RID, ROD) | Flex Dia. | Flex Hose (RF, UF) | Outlet Dia. | Outlet End Style | Length (in.) | Material (G, SS) | Drawing (Y/N) | Special Notes |
|--------|------------|---|-----------|--------------------|-------------|------------------|--------------|------------------|---------------|---------------|
| | | | | | | | | | | |
| | | | | | | | | | | |
| | | | | | | | | | | |
| | | | | | | | | | | |
| | | | | | | | | | | |



QUICK-FIT

THE WORLD'S FASTEST DUCTING

RUBBER FLEXIBLE HOSE

- Wide Temperature Range
- Versatility
- Better UV, Moisture and Weathering Resistance
- Will Not Set to The Shape of the Box When Packed
- Superior Chemical Resistance
- Better Abrasion Resistance
- Outstanding Flex Resistance
- Better Looking Product
- No Cement
- Air Tight

T-7



Size Range (in).....stock 2" to 24"
 Standard Length (ft)..... 25', 50'
 Standard Colors..... black
 Temp Range (°F)-60° to 275°

- Medium weight thermoplastic rubber hose reinforced with a spring steel wire helix
- Good abrasion resistance
- Designed for applications with wide temperature ranges
- Great moisture & UV resistance
- Excellent chemical resistance
- Smooth interior assures minimal friction loss & efficient air flow
- Wall Thickness = .030"
- Available in metric sizes, consult sales team on pricing & minimums



R-4



Size Range (in).....stock 2" to 24"
 Standard Length (ft)..... 10', 25', 50'
 Standard Colors..... clear
 Temp Range (°F) 20° to 160°

- Medium weight PVC hose reinforced with a spring steel wire helix
- Good for positive pressure applications
- Great compressibility
- Construction allows for value packaging by reducing the box size, reducing warehouse space & shipping costs
- Ideal for dust and woodworking applications
- Good chemical & moisture resistance
- Manufactured with FDA acceptable materials
- Wall Thickness = .028"

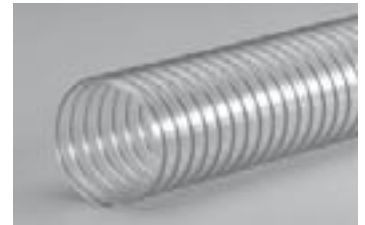

FLX-THANE® MD



Size Range (in).....stock 2" to 24"
 Standard Length (ft)..... 25', 50'
 Standard Colors..... black, clear
 Temp Range (°F)-60° to 225°

- Medium weight polyurethane hose reinforced with a bronze coated spring steel wire helix
- Good compressibility
- Great abrasion resistance & high tear strength
- Superior chemical resistance
- Excellent flexibility
- Designed for applications with wide temperature ranges
- Very good low temperature flexibility
- Clear is manufactured with FDA acceptable materials
- Available in metric sizes, consult sales team on pricing & minimums
- Wall Thickness = .030"





QUICK-FIT

THE WORLD'S FASTEST DUCTING

RIGID METAL FLEX HOSE

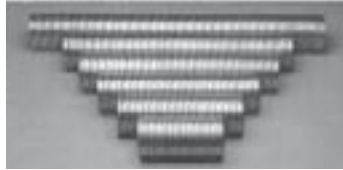

Part # 3281-XX00

| Inside Dia. (Inches) | Approx. Outside Dia. (Inches) | Min. CLR Bend Radius | Approx. Weight Per Foot (LBS) |
|----------------------|-------------------------------|----------------------|-------------------------------|
| 1 1/2 | 1 3/4 | 12.0 | 1.00 |
| 2 | 2 1/4 | 16.0 | 1.30 |
| 2 1/2 | 2 3/4 | 18.0 | 1.60 |
| 3 | 3 1/4 | 22.0 | 2.00 |
| 3 1/2 | 3 3/4 | 25.0 | 2.30 |
| 4 | 4 1/4 | 29.0 | 2.60 |
| 5 | 5 1/4 | 34.0 | 3.00 |

MEDIUM-HEAVY GALVANIZED OR STAINLESS

| Inside Dia. (Inches) | Approx. Outside Dia. (Inches) | Min. CLR Bend Radius | Approx. Weight Per Foot (LBS) |
|----------------------|-------------------------------|----------------------|-------------------------------|
| 6 | 6 1/4 | 44.0 | 3.60 |
| 7 | 7 1/4 | 50.0 | 4.20 |
| 8 | 8 1/4 | 56.0 | 4.70 |
| 9 | 9 1/4 | 61.0 | 5.30 |
| 10 | 10 1/4 | 65.0 | 5.90 |
| 12 | 12 1/4 | 76.0 | 7.00 |
| 14 | 14 1/4 | 106.0 | 8.10 |

.017- .020 Strip Thickness

ULTRA FLEX METAL HOSE

Part # 3283-XX00

| Inside Dia. (Inches) | Min. CLR Bend Radius | Approx. Weight Per Foot (LBS) |
|----------------------|----------------------|-------------------------------|
| 3 | 21 | 2.15 |
| 4 | 30 | 2.65 |
| 5 | 35 | 2.95 |

Manufactured in sizes ranging from 3" dia thru 8" dia of stainless steel or galvanized. Some Applications would include Air Handling, and Dust Collection.

| Inside Dia. (Inches) | Min. CLR Bend Radius | Approx. Weight Per Foot (LBS) |
|----------------------|----------------------|-------------------------------|
| 6 | 43 | 3.55 |
| 7 | 52 | 4.15 |
| 8 | 60 | 4.55 |

Square Lock: ID Tolerance: +1/4 " , - 0
 Specification: 3"-6" manufactured out of .019 material
 7"-8" manufactured out of .024 material

RIGID AND ULTRA FLEX STEEL HOSE CONFIGURATIONS

Steel Flex Hose With Raw Ends (Standard)

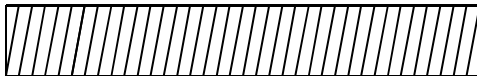

Steel Flex Hose With Q-F Ends (Custom)



Steel Flex Hose With Flange Ends (Custom)

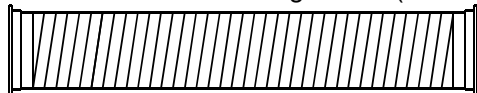

Steel Flex Hose With Raw Pipe Ends (Custom)

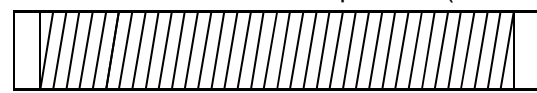

NOTE: When ordering steel hose, you have the option of having the hose fitted with several different style end fittings in any number of combinations. Raw hose is priced per foot, and sold only in 5 Ft. increments on 7" and above. 6" and below can be sold in any length. Contact your sales rep for pricing on specific lengths and end fittings.



NFES AUTOMATIC BLAST GATE

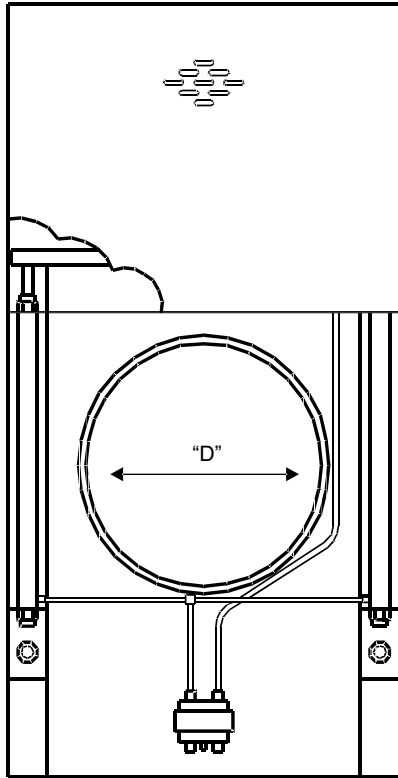

Wiring Diagram

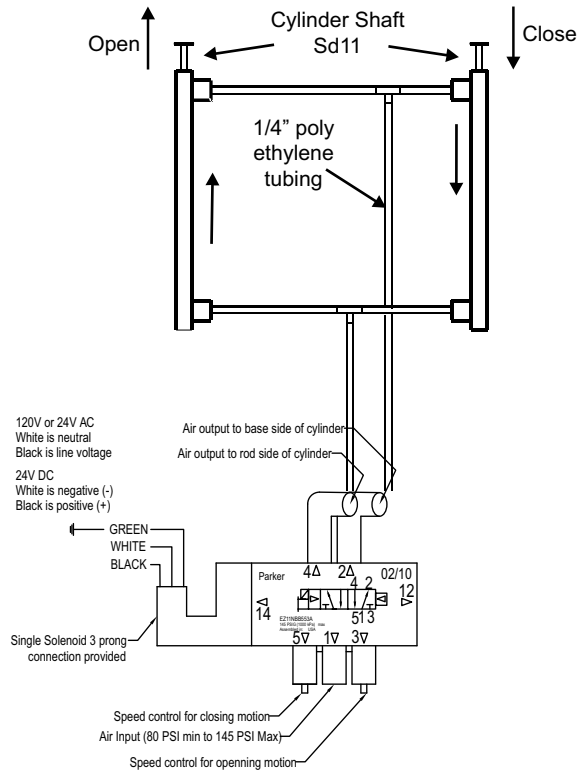

DESCRIPTION:

Automatic energy saving blast gates operated by double-acting compressed air cylinders. Cylinders are controlled by electrically-connecting solenoid to machines or remote switch. Gates are constructed with a special sealing device that reduces air loss and friction in operation.

APPLICATIONS:

Gates are used as energy-saving devices for industrial dust extraction where extraction is not always needed on a constant basis or where manual control needs to be eliminated.

AVAILABILITY:

Material: GALVANIZED or STAINLESS STEEL

Sizes in inch: 4, 5, 6, 7, 8, 9, 10, 12, 14, 16, 18, 20, 22, 24, 26

One cylinder Two cylinder

Part numbers: 3245-XX00 (where XX is the diameter)

Standard Requirements: 120 Volt power source and 80 psi minimum air pressure horizontally mounted. 240, 24 and 12 volt AC. 24 and 12 volt DC models also available upon request.

**QUICK-FIT****THE WORLD'S FASTEST DUCTING****NFES AUTOMATIC BLAST GATE****Temperature Rating:**

| | |
|--------|--|
| 120°F | Solenoid (solenoid is on the outside of the housing and may handle higher duct temperatures due to its location) |
| 140°F | Poly tube (poly tube is on the outside of the housing and may handle higher duct temperatures due to its location) |
| 158°F | Gasket Spring (intermittent to 250°F) |
| 165°F | Cylinder |
| 194°F | 3M #540 Polyurethane Sealant (collar adhesive) |
| 200°F | UHMW Seal |
| 250°F | Optional Oil Mist - 3M 2084 Scotch Seal Metal Sealant |
| 375°F | Optional Epoxy Caulk - 3M DP460 |
| 500°F | Galvanized Parts: with little or no breakdown of zinc - zinc melting point is 740°F |
| 1100°F | 304SS: bluing may occur at temperatures of 800°F and above |

Material Specifications:

| | |
|------------------|---|
| Galvanized Body: | Galvanized is ASTM A527 with a G-90 rating |
| 304SS Body: | finish meets ASTM A240 |
| 314SS Body: | Finish meets ASTM A240 |
| UHMW Seal: | Ultra High Molecular Weight |
| Gasket Spring: | Poron® Cellular Urethane material |
| Cylinders: | Crimped round body, 304 Stainless Steel tube only, Aluminum end caps, Non-repairable Bore size is 1-1/16" Ports are 1/8" NPT Standard Piston rod diameter is 0.312" Piston rod material: 304 Stainless steel only Single acting end Standard fluid: Filtered air Operating medium: Pneumatic, 250 PSI maximum (normal operating pressure is (80 PSI minimum) |
| Poly tube: | 1/4" OD x 0.040 wall poly tube, 120 PSI, Grade E5 LIP, Type 1 |
| Solenoid: | 0.8Cv flow characteristics 1/8" NPT ports Solenoid is constant pressure |

Structural Integrity:

Automatic, energy saving blast gates are operated by double acting compressed air cylinders
Cylinders are controlled by electrically-connected solenoid to machines or remote switch
Standard hookup is 120 volt AC
Optional: 24 volt AC (Must be stated on PO)
Optional: 24 volt DC (Must be stated on PO)
Single cylinder gates: 3" up to 8" diameters
Double cylinder gates: 9" and up diameters (second cylinder depicted by phantom lines)



QUICK-FIT

THE WORLD'S FASTEST DUCTING

SD AUTOMATIC BLAST GATE

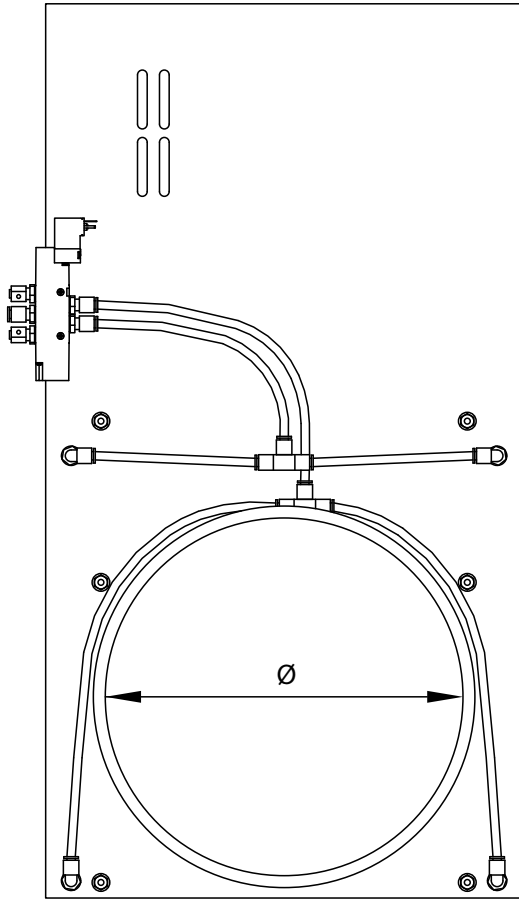

Wiring Diagram

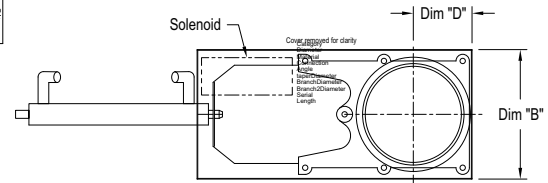
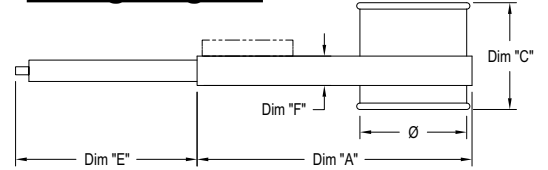
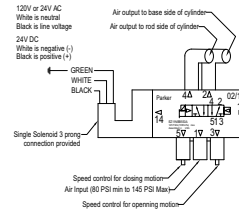

Single Cylinder

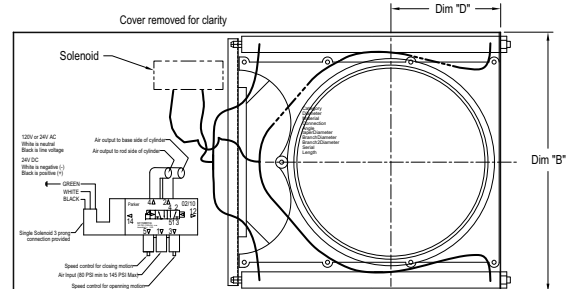
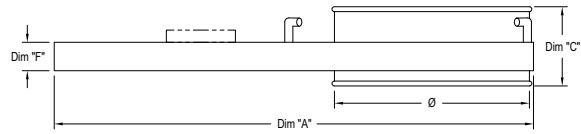

Double Cylinder

DESCRIPTION:

Automatic standard duty blast gates operated by double-acting compressed air cylinders. The SD version is a less expensive alternative to the NFES gate due to omission of the seals. Cylinders are controlled by electrically-connecting solenoid to machines or remote switch.

APPLICATIONS:

Gates are used as energy-saving devices for industrial dust extraction where extraction is not needed on a constant basis and where manual control needs to be eliminated.

AVAILABILITY:

Material: GALVANIZED
 Sizes in inch: 4, 5, 6, 7, 8, 9, 10, 12, 14, 16, 18, 20, 22, 24

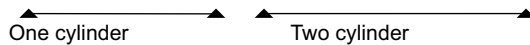

Part numbers: 3242-XX00 (where XX is the diameter)
 Standard Requirements: 120 Volt power source and 80 psi minimum air pressure horizontally mounted.
 240, 24 and 12 volt AC. 24 and 12 volt DC models also available upon request.

**QUICK-FIT****THE WORLD'S FASTEST DUCTING****SD AUTOMATIC BLAST GATE****Temperature Rating:**

| | |
|--------|--|
| 120°F | Solenoid (solenoid is on the outside of the housing and may handle higher duct temperatures due to its location) |
| 140°F | Poly tube (poly tube is on the outside of the housing and may handle higher duct temperatures due to its location) |
| 165°F | Cylinder |
| 194°F | 3M #540 Polyurethane Sealant (collar adhesive) |
| 250°F | Optional Oil Mist - 3M 2084 Scotch Seal Metal Sealant |
| 375°F | Optional Epoxy Caulk - 3M DP460 |
| 500°F | Galvanized Parts: 18ga or thicker - cannot be changed |
| 1100°F | 304SS: 18ga or thicker - cannot be changed - bluing may occur at temperatures of 800°F and above |

Material Specifications:

| | |
|------------------|---|
| Galvanized Body: | Galvanized is ASTM A527 with a G-90 rating |
| 304SS Body: | Stainless is 304 with a finish meeting ASTM A240 - Keeps alum cast housing & replaces galv'd parts with 304SS |
| 314SS Body: | Stainless is 316 with a finish meeting ASTM A240 - Keeps alum cast housing & replaces galv'd parts with 316SS |
| Gasket Spring: | Poron® Cellular Urethane material |
| Cylinders: | Crimped round body, 304 Stainless Steel tube only, Aluminum end caps, Non-repairable Bore size is 1-1/16" Ports are 1/8" NPT Standard Piston rod diameter is 0.312" Piston rod material: 304 Stainless steel only Single acting end Standard fluid: Filtered air Operating medium: Pneumatic, 250 PSI maximum (normal operating pressure is (80 PSI minimum) |
| Poly tube: | 1/4" OD x 0.040 wall poly tube, 120 PSI, Grade E5 LIP, Type 1 |
| Solenoid: | 0.8Cv flow characteristics 1/8" NPT ports Solenoid is constant pressure |

Structural Integrity:

Automatic, energy saving blast gates are operated by double acting compressed air cylinders. Cylinders are controlled by electrically-connected solenoid to machines or remote switch. Standard hookup is 120 volt AC
 Optional: 24 volt AC (Must be stated on PO)
 Optional: 24 volt DC (Must be stated on PO)
 Single cylinder gates: 3" up to 8" diameters
 Double cylinder gates: 9" and up diameters (second cylinder depicted by phantom lines)

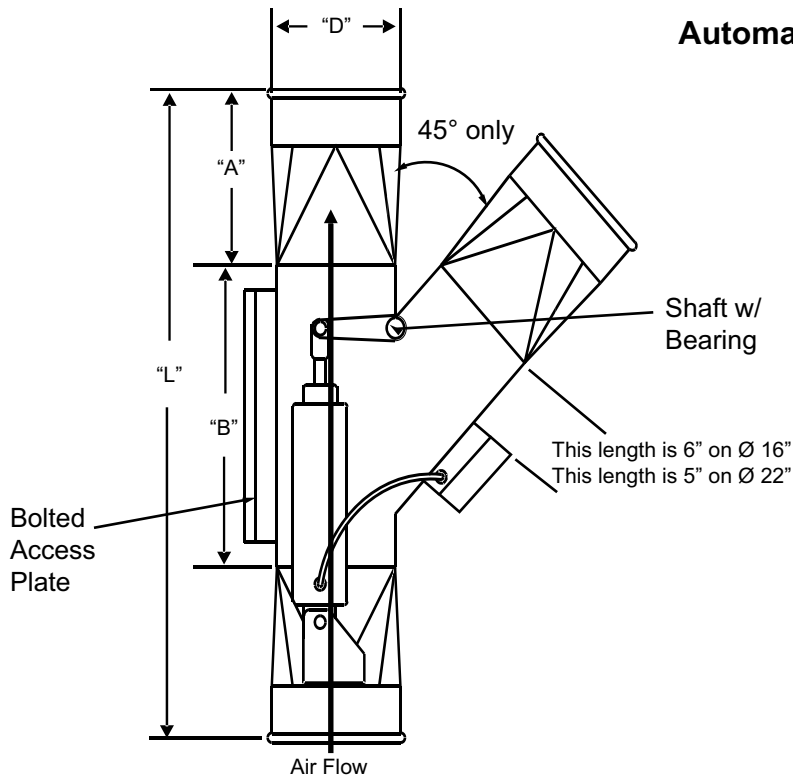
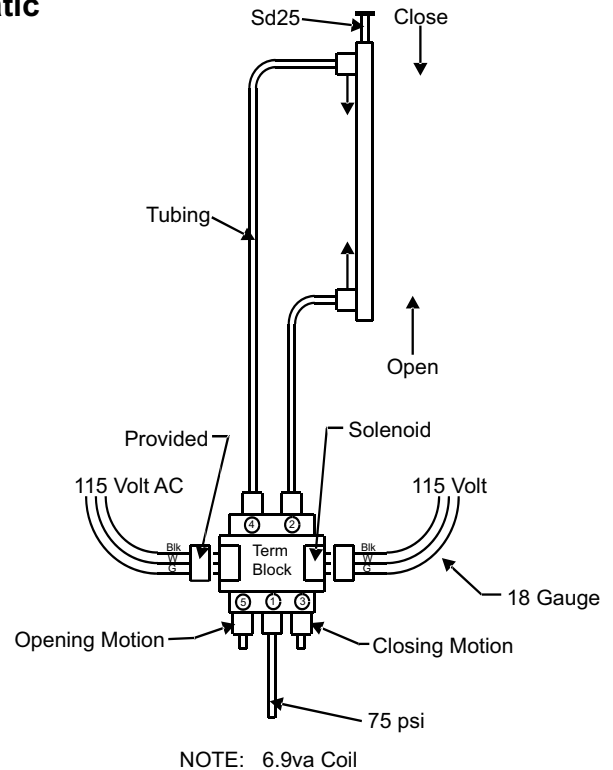
**QUICK-FIT****THE WORLD'S FASTEST DUCTING****DIVERTER VALVE****Automatic****DESCRIPTION:**

Highly efficient, economical method of diverting flow of material or air. Designed with Q-F or flanged, manual, or air operated.

APPLICATIONS:

Diverter valves are used for diverting material or air to one of two possible directions at a time.

AVAILABILITY:

Material: BLACK METAL or STAINLESS STEEL 3/16" thick
 Sizes in inch: 3, 4, 5, 6, 7, 8, 9, 10, 11, 12, 13, 14, 15, 16, 17, 18, 20, 22, 24
 Larger sizes available upon request.

Please NOTE: 45 lateral angle only

Part numbers: 3235-XX00 for manual (where XX is the diameter)
 3236-XX00 for automatic, PLUS read "Special".

Standard Requirements: 120 Volt power source and 75 psi minimum air pressure.
 240, 24 and 12 volt AC as well as 24 and 12 volt DC models are available upon request.

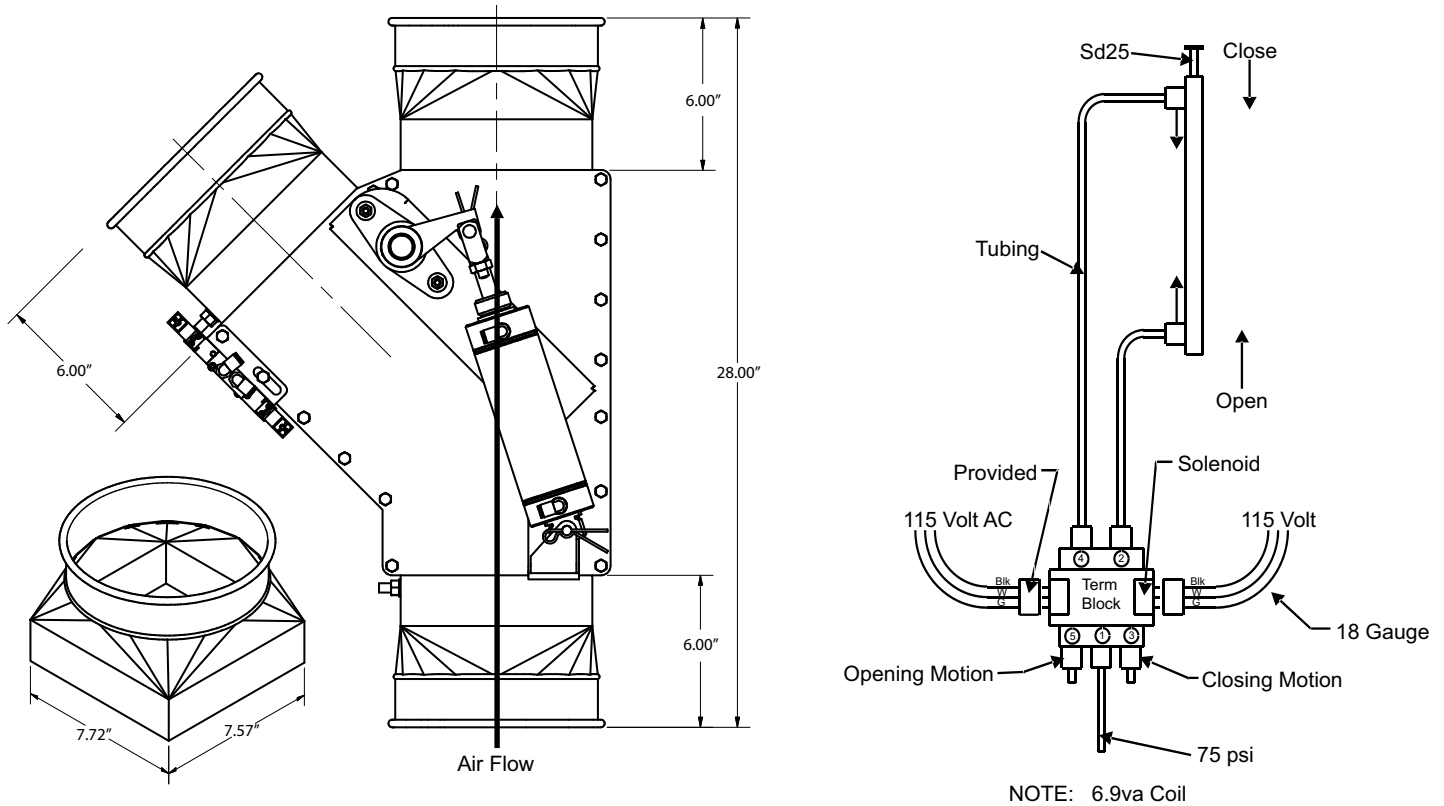
**QUICK-FIT****THE WORLD'S FASTEST DUCTING****SD DIVERTER VALVE****DESCRIPTION:**

Highly efficient, economical method of diverting flow of material or air. Designed with Q-F or flanged, manual, or air operated. Lighter weight than our heavy duty diverter valve.

APPLICATIONS:

Diverter valves are used for diverting material or air to one of two possible directions at a time.

AVAILABILITY:

Material: GALVANIZED or STAINLESS STEEL, 14ga construction

Sizes in inch: 3, 4, 5, 6, 7, 8, 9, 10, 11, 12, 13

Larger sizes available upon request.

Please NOTE: 45 lateral angle only

Part numbers: 3233-XX00 for manual (where XX is the diameter)

3234-XX00 for automatic, PLUS read "Special".

Standard Requirements:

120 Volt power source and 75 psi minimum air pressure.

240, 24 and 12 volt AC as well as 24 and 12 volt DC models are available upon request.



QUICK-FIT

THE WORLD'S FASTEST DUCTING

- The arm is flexible in all directions and simple to position
- Designed for wall mounting with integrated wall bracket/90° bend
- Can be rotated 180°
- Can be equipped with a damper placed in the bend as an accessory
- The hood can be tilted in all directions

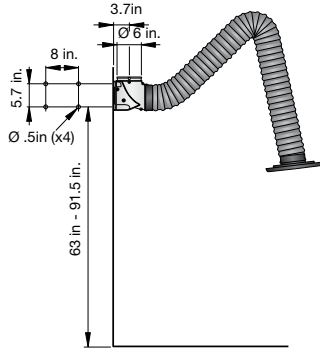

Nordfab standard extraction arm is specially designed for working environments with fumes, vapors or non-explosive dust, where the demands for higher airflows and temperatures are moderate. Typical workplaces can be welding schools and different types of applications in light production. The applications can be welding, grinding, or other industrial processes where an easily positioned arm is required. The arm is available in two lengths, 2 and 3 m, and equipped with a high efficiency extraction hood.

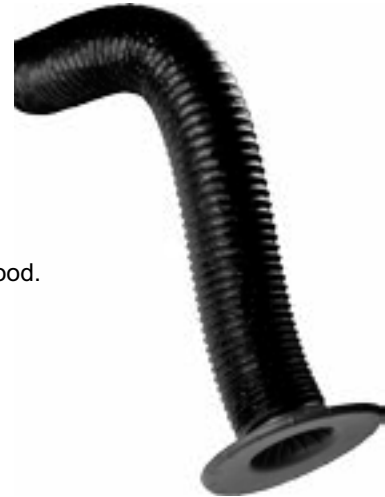

| Description | Working range, ft | Airflow, CFM | Connection Ø, in | Max. fume temperature, °F | Noise level at hood, dB(A) | Weight, lbs |
|----------------------|-------------------|--------------|------------------|---------------------------|----------------------------|-------------|
| Standard arm, 6.5 ft | 6.5 | 353-530 | 6 | 158 | 67 | 24 |
| Standard arm, 10 ft | 10 | 353-530 | 6 | 158 | 67 | 29 |

Extraction arm Original



It is specially designed for working environments with fumes, vapors or non-explosive dust. Typical workplaces are the metal fabrication industry or other types of industries where extraction is needed. The applications can be welding, grinding, or other industrial processes where an easily positioned arm is required. The product is equipped with a damper in the hood as standard.

- A swivel allows the product to rotate 360°.
- The arm is flexible in all directions and simple to position.
- The product is equipped with a damper in the hood as standard.
- The hood on all models can be tilted in all directions.

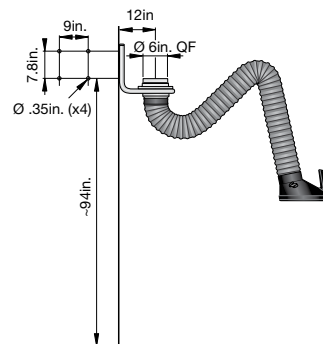

| Description | Working range, ft | Airflow, CFM | Connection Ø, in | Max. fume temperature, °F | Noise level at hood, dB(A) | Weight, lbs |
|--------------------------------|-------------------|--------------|------------------|---------------------------|----------------------------|-------------|
| Original arm 6.5 ft | 6.5 | 412-589 | 6 | 158 | 63-75 | 24 |
| Original arm 10 ft | 10 | 412-589 | 6 | 158 | 63-75 | 28 |
| Original arm 13 ft, vertical | 13 | 412-589 | 6 | 158 | 63-75 | 35 |
| Original arm 13 ft, horizontal | 13 | 412-589 | 6 | 158 | 63-75 | 35 |



QUICK-FIT

THE WORLD'S FASTEST DUCTING

**JET CAP
NO LOSS STACKHEAD**

JET CAP

| Ø | PART NO. | ENDS | W (inches) | H (inches) |
|-----|-----------|--------|---------------|---------------|
| 6" | 3258-0600 | QF | 10.12 | 14.40 |
| 8" | 3258-0800 | QF | 13.25 | 18.40 |
| 10" | 3258-1000 | QF | 16.50 | 22.40 |
| 12" | 3258-1200 | QF | 20.00 | 27.00 |
| 13" | 3258-1300 | QF | 21.50 | 30.00 |
| 14" | 3258-1400 | QF | 23.12 | 32.80 |
| 15" | 3258-1500 | QF | 24.50 | 34.00 |
| 16" | 3258-1600 | QF | 26.50 | 36.40 |
| 17" | 3258-1700 | QF | 27.70 | 38.00 |
| 18" | 3258-1800 | QF | 29.50 | 40.00 |
| 20" | 3258-2000 | QF | 32.50 | 44.40 |
| 22" | 3258-2200 | QF | 35.40 | 47.50 |
| 24" | 3258-2400 | QF | 38.60 | 51.50 |
| 26" | 3258-2600 | FLANGE | 42.20 | 55.00 |
| 28" | 3258-2800 | FLANGE | 45.20 | 59.00 |
| 30" | 3258-3000 | FLANGE | 48.20 | 63.00 |
| 32" | 3258-3200 | FLANGE | 51.20 | 67.00 |
| 34" | 3258-3400 | FLANGE | 54.60 | 71.00 |
| 36" | 3258-3600 | FLANGE | 58.20 | 74.70 |
| 38" | 3258-3800 | FLANGE | 61.20 | 79.00 |
| 40" | 3258-4000 | FLANGE | 64.20 | 83.00 |

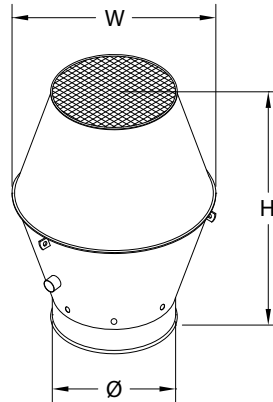

- Prevents rain from entering duct work
- Inner funnel piece allows rain to drain out of ductwork even when system is not running
- Has three angle brackets for guide wire attachment
- Installs In Seconds with Standard Q-F Clamp

NO-LOSS STACKHEAD

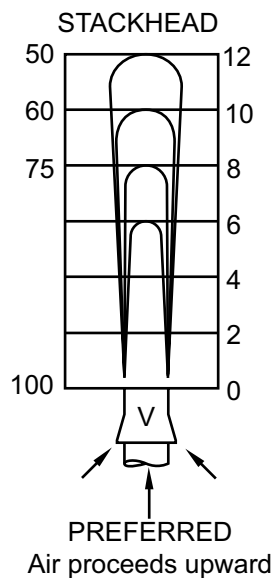
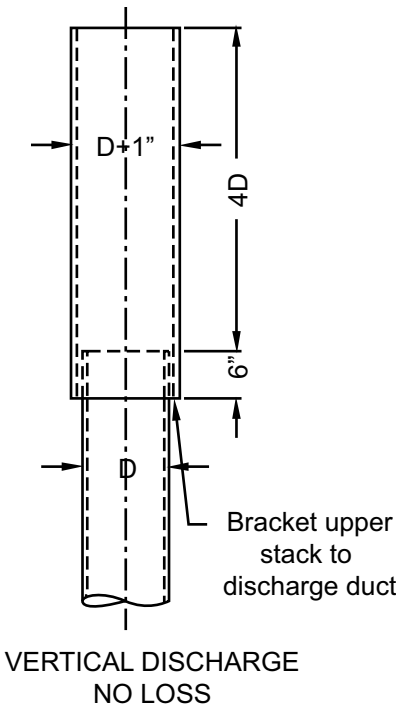

Angle Flange used for securing with guyed wires



QF Connection

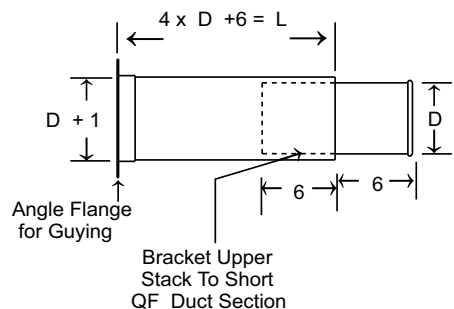

Recommended Industrial Ventilation Guidelines



QUICK-FIT

THE WORLD'S FASTEST DUCTING

Explosion Isolation Flap

The Standards

Various NFPA standards require that a dust collection system has a means of preventing the transmission of energy from a fire or explosion to the building/work area. Through extensive testing by a third party testing facility, Nordfab has developed the Explosion Isolation Flap (EIF) type CARZ to be installed upstream of the dust collector.

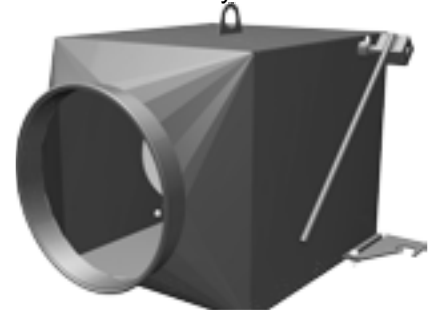

Without EIF



With EIF

How it works

Under normal operation the flap will open as the downstream air moving device generates a flow in the ductwork. Should an explosion happen in the downstream equipment - like a dust collector - a pressure front develops in the ductwork within milliseconds and due to the design of the EIF, the internal flap will be forced closed and seal off the approaching flame front. This prevents glowing embers and burning material from entering into upstream equipment and spaces.

The Design

The design of the EIF is critical as the flap must function in milliseconds and therefore must be of light construction but must be strong enough to withstand the explosion pressure.

Many full scale tests were performed to arrive at the proper design and assure proper function.

The Tests

Since the EIF is a safety device, Nordfab submitted the EIF to rigorous testing by an accredited testing facility in accordance with 94/9/EC Directive.



Label: ATS.096 CARZ (0126-0500) CE1180 Ex D St1
 Label: ATS.098 CARZ (0560-01000)

The marking is based on product certification by N.B. 1026.

The certificates allow max P_{red} 0.5 bar pressure resistance for sizes dia 22" (560mm) and smaller. Sizes 630mm-1000mm: 0.30 bar



Normal Operation

Explosion/deflagration



QUICK-FIT

THE WORLD'S FASTEST DUCTING

Application:

Material Types: Dry Dusts (not designed for combustible gas and vapors and hybrid mixtures of these substances.)

Kst Value of Dust < 200 Bar-M / Sec
NOT SUITABLE for greater than ST1 dust.

Transport Medium: Standard Air

Air Velocity In the Device: > than the minimum transport velocity of the conveyed dust.

Design conditions for ductwork and Air Material Separator (Dust Collector)

| EIF Designed for Max. Reduced Pressure P _{red} | |
|---|------------------|
| Size | P _{red} |
| CARZ 6"-22" | 0.5 bar |
| CARZ 24"-40" AF | 0.3 bar |

Installation:

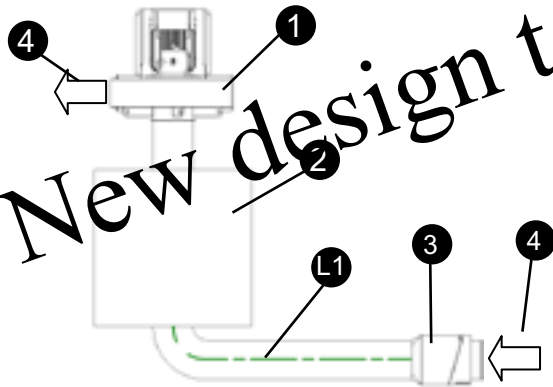

New design to be released in Q2

- 1 Fan
- 2 Vessel (filter, container, silo, ect.)
- 3 CARZ Explosion Isolation Flap
- 4 Normal process flow
- L1 Installation distance from vessel, where explosion could occur

| Min. Distance Between EIF and AMS | | |
|-----------------------------------|-------|-------|
| Size | Min A | Max A |
| CARZ 6"-20" | 7' | 16' |
| CARZ 24" - 40" AF | 16' | 28' |

KST verification form required / Lead time is 25 working days after receipt.

Dimensions:

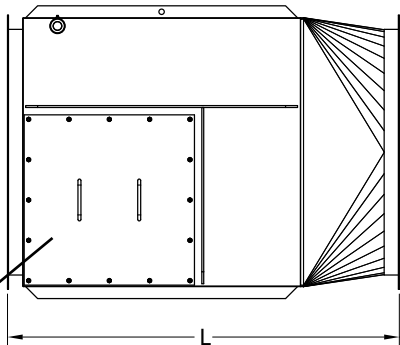
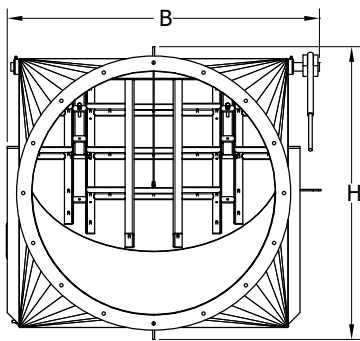

Inspection door 22" and larger

| Actual diameter | Length (L) | Body (B) | Weight (lbs) |
|-----------------|------------|----------|--------------|
| 6" | 19 1/4" | 16 7/8" | 29 |
| 7" | 20 1/8" | 17 5/8" | 35 |
| 8" | 21" | 18 7/16" | 42 |
| 10" | 23" | 20 7/16" | 44 |
| 12" | 25 1/2" | 23" | 60 |
| 14" | 27" | 24 3/8" | 73 |
| 16" | 29" | 26 3/8" | 93 |
| 18" | 31" | 28 3/8" | 99 |
| 20" | 33" | 30 1/4" | 108 |
| 22" | 42 1/4" | 32" | 176 |
| 24" AF | 44 7/16" | 34 3/4" | 229 |
| 28" AF | 48" | 38" | 267 |
| 32" AF | 51 5/8" | 41 1/2" | 309 |
| 36" AF | 55 1/2" | 45 3/8" | 353 |
| 40" AF | 59 1/2" | 49 3/8" | 397 |

Above dimension chart is for general information. Please consult factory for dimensions based on the connection options



QUICK-FIT

THE WORLD'S FASTEST DUCTING

INSTALLING TAP-IN OR CUT-IN

STEP 1:

Temporarily place the in-cut on the main trunk in the required position, and while holding in place, place hand inside of branch and trace the interior of the branch on trunk line where it needs to be cut out.

STEP 2:

Take down in-cut and drill a starter hole in the main trunk along the line traced from the branch. Then using metal snips or a reciprocating saw, cut out metal piece that has been traced. File or grind any sharp edges to insure efficient flow.

STEP 3:

Now use an industrial strength silicone sealant to seal between in-cut base and main trunk.

STEP 4:

Use small sheet metal screws or a banding type clamp material to secure in-cut to the main trunk line.

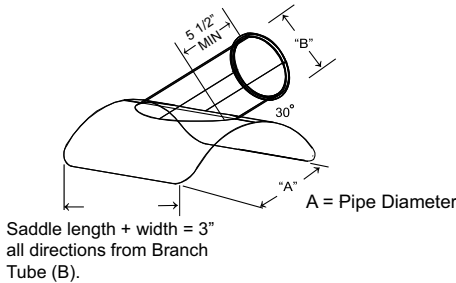

NOTE: Gauge based on "A"

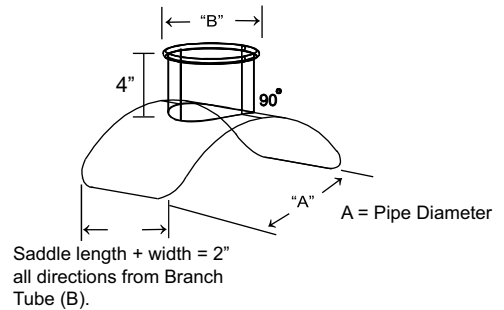

INLINE SILENCER

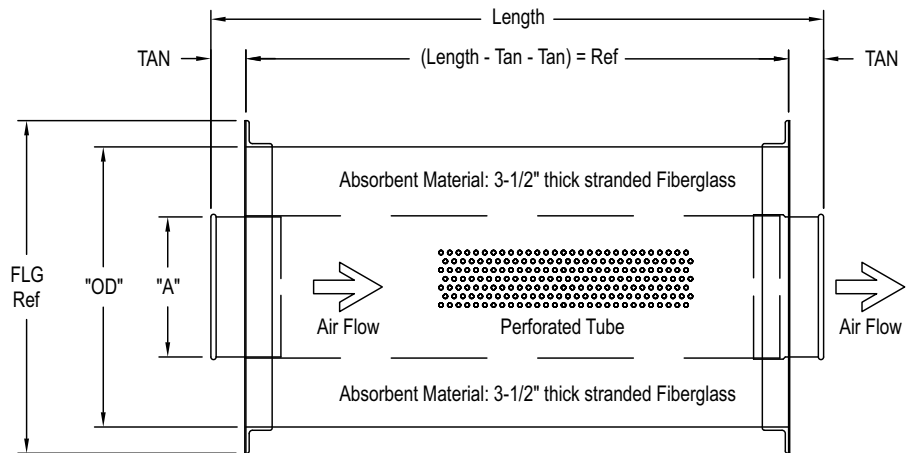
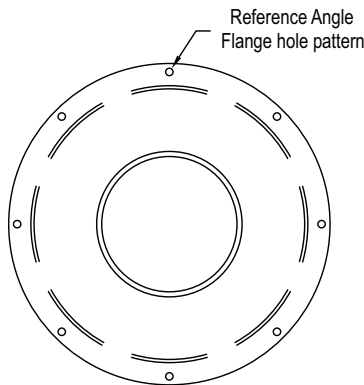

1. Silencer to be placed in process line down stream of fan or cyclone collector.
2. Silencer housing constructed of 18-20 gauge galvanized metal.
3. Silencer should be properly supported in process line.
4. NORDFAB reserves the right to modify the design of the silencer without notice.
5. Efficiencies of Silencer have not been tested, nor are there any guarantees of sound level attenuation.

**QUICK-FIT****THE WORLD'S FASTEST DUCTING****INLINE SILENCER (cont.)**

| "A" | "OD" | PART NO. | ENDS | LENGTH (C) | GAUGE HOUSING | WEIGHT (GALV) |
|-----|------|-----------|--------|------------|---------------|---------------|
| 3" | 12" | 3106-0300 | QF | 28" | 20 | 10.00 |
| 4" | 12" | 3106-0400 | QF | 28" | 20 | 21.00 |
| 5" | 13" | 3106-0500 | QF | 28" | 20 | 35.00 |
| 6" | 14" | 3106-0600 | QF | 30" | 20 | 43.00 |
| 7" | 15" | 3106-0700 | QF | 30" | 20 | 54.00 |
| 8" | 16" | 3106-0800 | QF | 35" | 20 | 65.00 |
| 9" | 17" | 3106-0900 | QF | 40" | 20 | 76.00 |
| 10" | 18" | 3106-1000 | QF | 48" | 20 | 89.00 |
| 12" | 20" | 3106-1200 | QF | 54" | 20 | 104.00 |
| 14" | 22" | 3106-1400 | QF | 60" | 20 | 122.00 |
| 16" | 24" | 3106-1600 | QF | 64" | 20 | 176.00 |
| 18" | 26" | 3106-1800 | QF | 68" | 20 | 225.00 |
| 20" | 28" | 3106-2000 | QF | 72" | 20 | 265.00 |
| 22" | 30" | 3106-2200 | QF | 76" | 18 | 310.00 |
| 24" | 32" | 3106-2400 | QF | 80" | 18 | 406.00 |
| 26" | 34" | 3106-2600 | FLANGE | 80" | 18 | 546.00 |
| 28" | 36" | 3106-2800 | FLANGE | 80" | 18 | 600.00 |
| 30" | 38" | 3106-3000 | FLANGE | 80" | 18 | 678.00 |
| 32" | 40" | 3106-3200 | FLANGE | 80" | 18 | 700.00 |
| 34" | 42" | 3106-3400 | FLANGE | 80" | 18 | 770.00 |
| 36" | 44" | 3106-3600 | FLANGE | 80" | 18 | 897.00 |
| 38" | 46" | 3106-3800 | FLANGE | 80" | 18 | 974.00 |
| 40" | 48" | 3106-4000 | FLANGE | 80" | 18 | 1,118.00 |

Material Specifications:

| | |
|------------------|------------------------------|
| Galvanized: | ASTM A527 with a G-90 rating |
| Perforated Tube: | ASTM A653 |
| 304SS: | Finish meets ASTM A240 |
| 316SS: | Finish meets ASTM A240 |

Absorbent Material:

3-1/2" thick fiberglass stranded bats

Structural Integrity:

Outer Tube: Longitudinal seam is laser welded to 15" diameter pipe and lock formed 16" and greater

Air flow directional:

Yes - arrows are painted on product for installation.

Special Notes:

Standard QF end can be changed to RawID, RawOD, No Fitting, Hose Adapter, Flat Flange, and Angle Flange.



QUICK-FIT
THE WORLD'S FASTEST DUCTING

SLIDING ACCESS PANEL MIST RECYCLER



Closed position Partially Open Fully Open

SLIDING ACCESS PANEL

The 7" dimension of the opening is measured around the pipe as shown. Because of this panels are not available under 6".



| Ø | Pipe Length/Slide Length | Access Hole | Part Number |
|--------|--------------------------|-------------|------------------|
| 6"-8" | 59.25 inches/18 Inches | 7" x 14" | 3103-XX00-100000 |
| 9"-24" | 58.75 inches/18 Inches | 7" x 14" | 3103-XX00-100000 |

The SAP consists of a standard length of QF pipe with an access opening laser cut into it, a pre-mounted 18-inch sleeve with two clamps and two rubber o-rings that covers and allows access.

MIST RECYCLER

| Ø | PART NO. | GAUGE | (A) INCH | (B) INCH | BAFFLE SIZE | WEIGHT (GALV) |
|-----|-----------|-------|----------|----------|-------------|---------------|
| 3" | 3192-0300 | 22 | 14.00 | 18.00 | 10" x 14" | 11.10 |
| 4" | 3192-0400 | 22 | 14.00 | 18.00 | 10" x 14" | 11.25 |
| 5" | 3192-0500 | 22 | 14.00 | 18.00 | 10" x 14" | 11.45 |
| 6" | 3192-0600 | 22 | 14.00 | 18.00 | 10" x 14" | 11.60 |
| 7" | 3192-0700 | 22 | 20.00 | 24.00 | 16" x 20" | 22.70 |
| 8" | 3192-0800 | 22 | 20.00 | 24.00 | 16" x 20" | 22.85 |
| 9" | 3192-0900 | 22 | 20.00 | 24.00 | 16" x 20" | 23.10 |
| 10" | 3192-1000 | 22 | 20.00 | 24.00 | 16" x 20" | 23.30 |
| 11" | 3192-1100 | 22 | 20.00 | 28.00 | 20" x 20" | 32.65 |
| 12" | 3192-1200 | 22 | 20.00 | 28.00 | 20" x 20" | 32.85 |

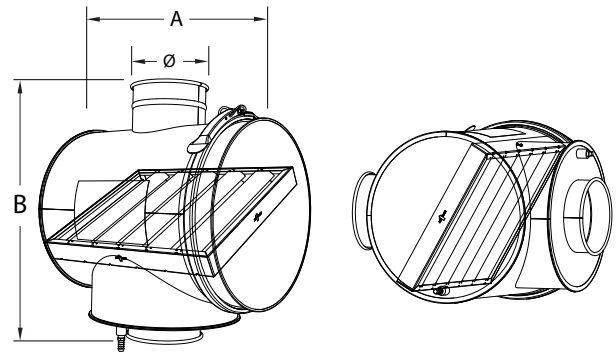

DESCRIPTION:

The Nordfab Mist Recycler (MR) can extend filter media life, reduce maintenance costs and decrease issues caused by excessive fluids in the system..

APPLICATIONS:

Mist recyclers are used to extract mist particles from the air to be recycled back to the machine. The baffle acts as a system prefilter and mechanically extracts droplets and mist from the airstream. Liquid collected in the MR drains into a sump and is returned to the machine via a drain port.

AVAILABILITY:

Material: GALVANIZED OR SS304



QUICK-FIT

THE WORLD'S FASTEST DUCTING

GRIPPLE HANG-FAST

Gripple Hang-Fast is a complete solution for hanging mechanical and electrical services. It comes as a ready-to-use suspension kit, with load ratings from 22lbs to 715lbs. The comprehensive range ensures that installation times are minimized and high productivity is achieved on site.

The principal element of all Gripple Hang-Fast assemblies is the Gripple Hang-Fast Grip, which is not only used to terminate the rope but is also the means by which object height can be adjusted.

Gripple Hang-Fast
Sizes & Working Load Limits ...

| ITEM # | LENGTH | WEIGHT | AVAILABILITY |
|------------------|--------|---------|--------------|
| 3266-1500-022LBS | 15' | 22 LBS | IN STOCK |
| 3266-1500-100LBS | 15' | 100 LBS | IN STOCK |
| 3266-1500-200LBS | 15' | 200 LBS | IN STOCK |
| 3266-1500-495LBS | 15' | 495 LBS | IN STOCK |
| 3266-1500-715LBS | 15' | 715 LBS | IN STOCK |

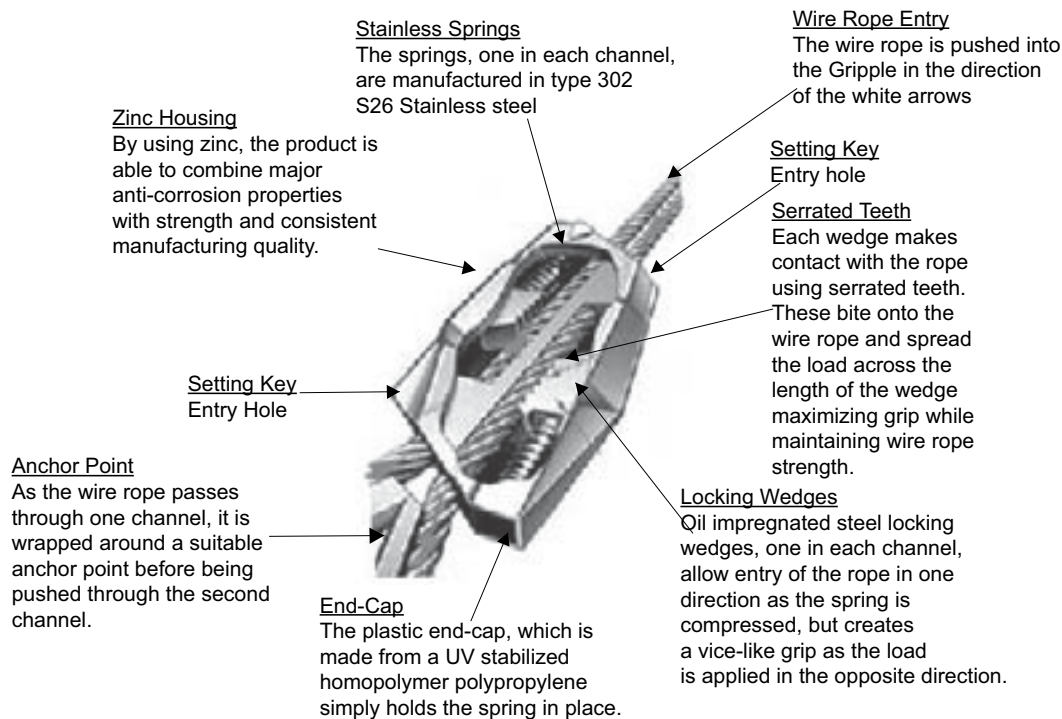



QUICK-FIT

THE WORLD'S FASTEST DUCTING

TYPICAL WALL MOUNTING BRACE

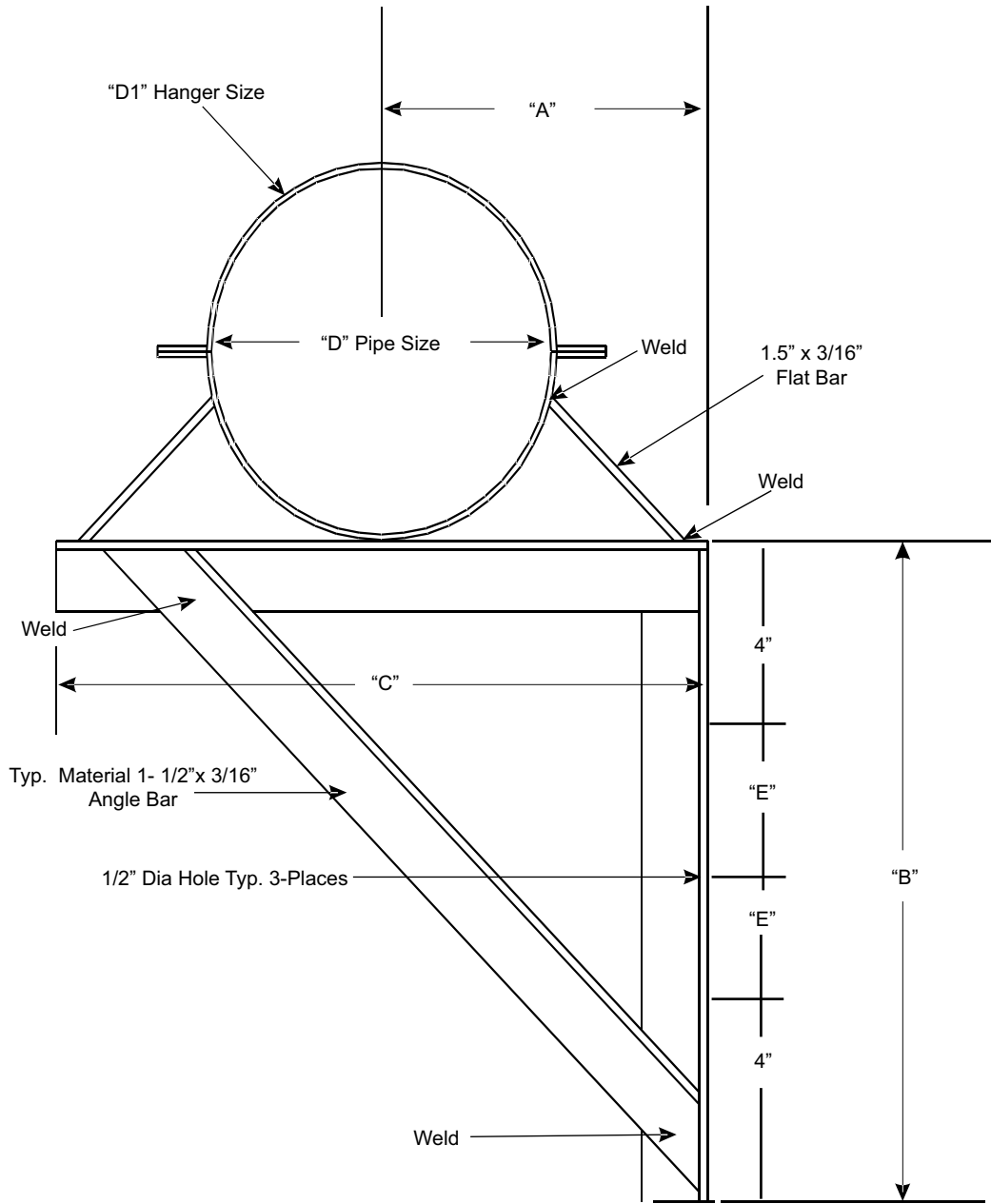

| QTY | "A" | "B" | "C" | "D1" | "D" | "E" |
|-----|-----|-----|-----|------|-----|-----|
| | | | | | | |
| | | | | | | |
| | | | | | | |
| | | | | | | |
| | | | | | | |



QUICK-FIT

THE WORLD'S FASTEST DUCTING

TYPICAL CEILING HANGING METHOD

(Check local building codes, Nordfab is not responsible for building code violations)

Gripple hangers are also a typical ceiling hanging method.

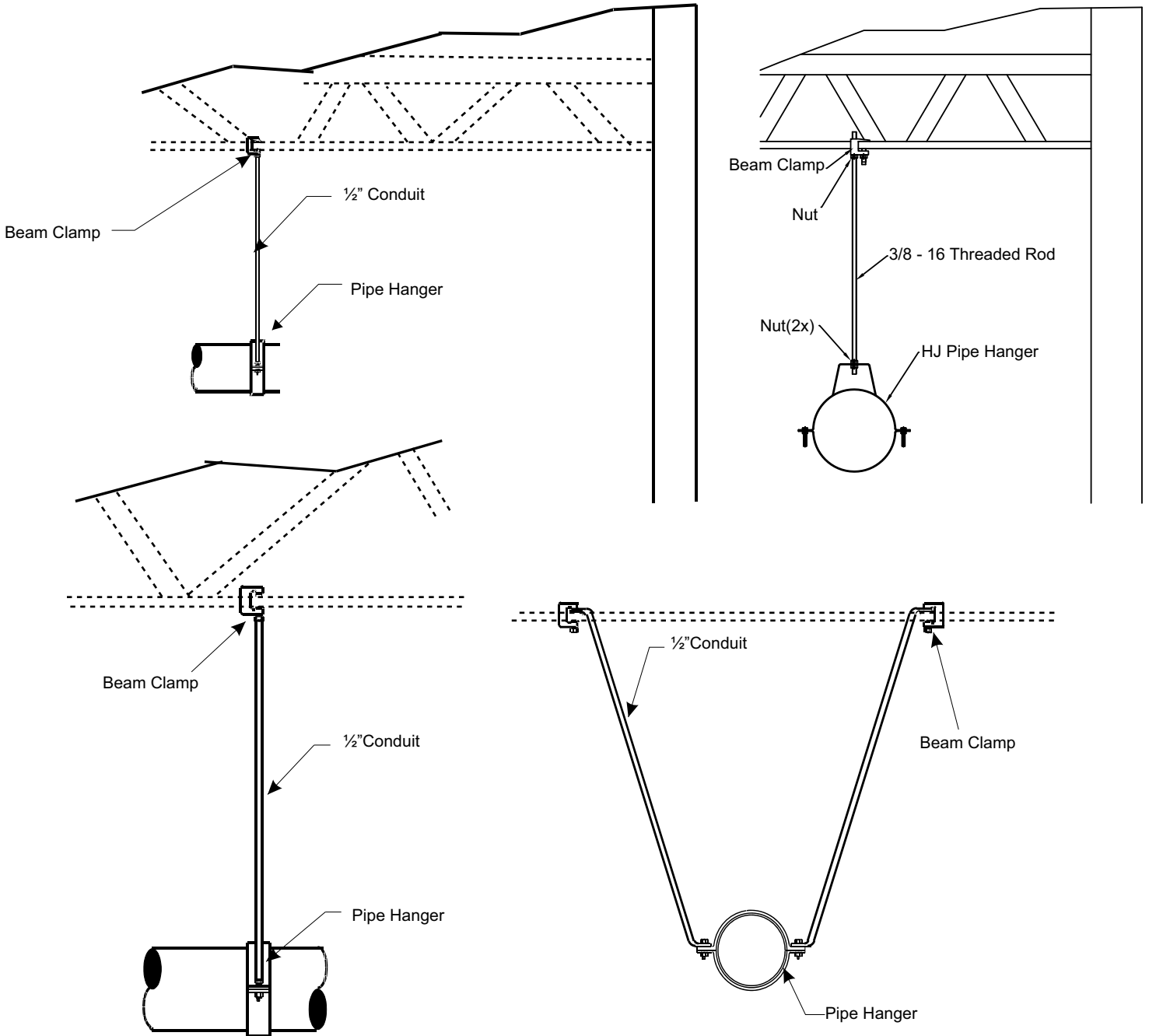

NOTE: Refer to your local codes when choosing how to support QF ducting.



QUICK-FIT

THE WORLD'S FASTEST DUCTING

TYPICAL DRY SYSTEM INSTALLATION

TYPICAL DROP FOR DRY SYSTEMS

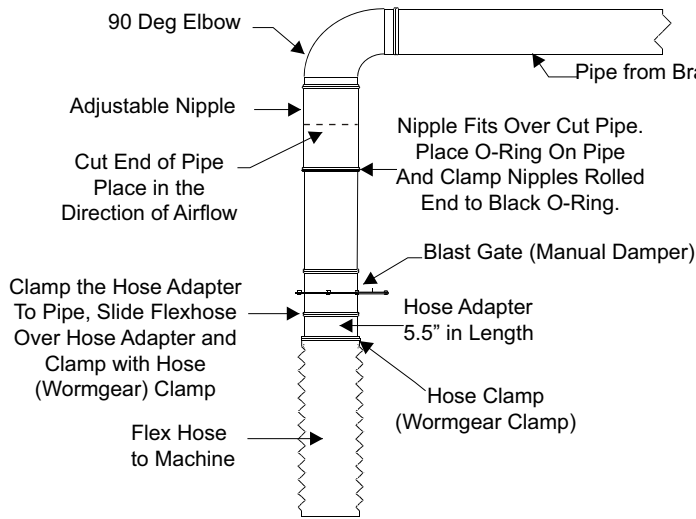

PLAN VIEW

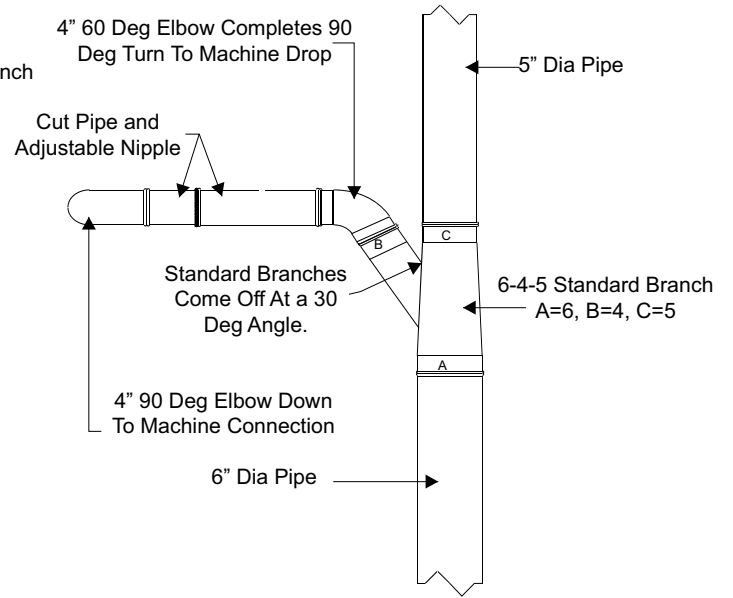

ELEVATION VIEW

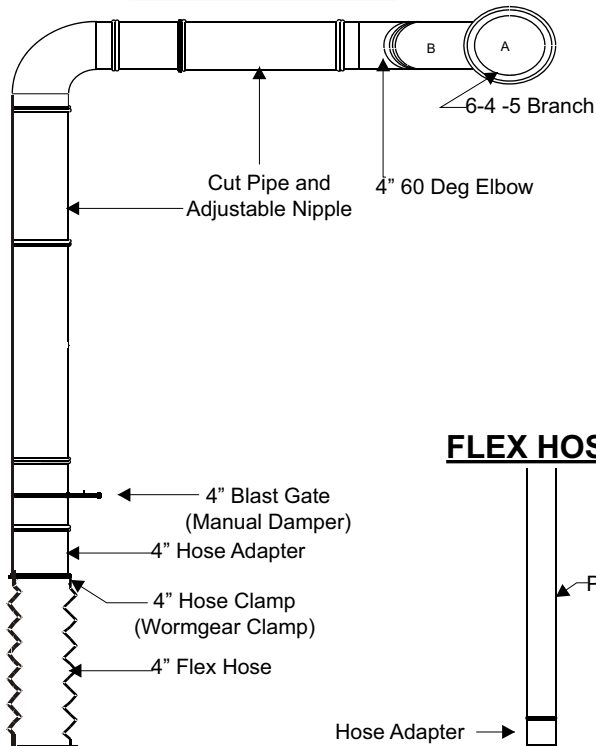

HARD DUCT TO MACHINE

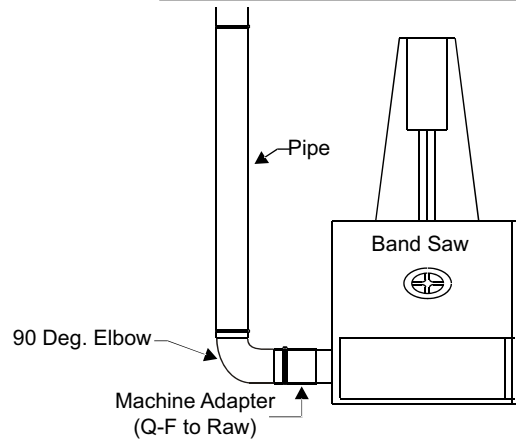

FLEX HOSE TO MACHINE

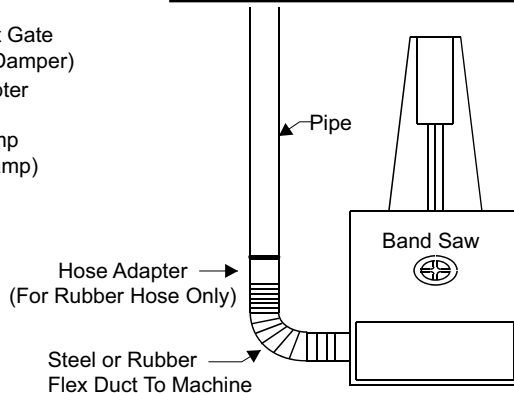



QUICK-FIT
THE WORLD'S FASTEST DUCTING

TYPICAL WET SYSTEM INSTALLATION

TYPICAL DROP FOR WET SYSTEMS

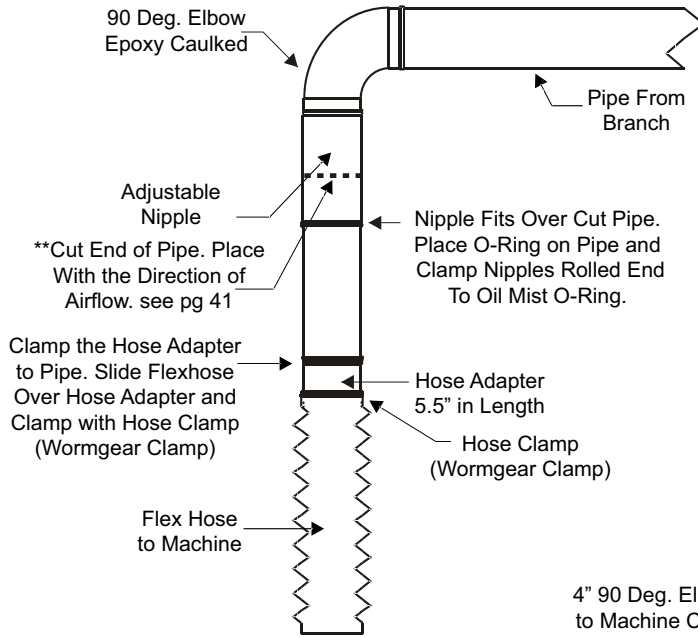

ELEVATION VIEW

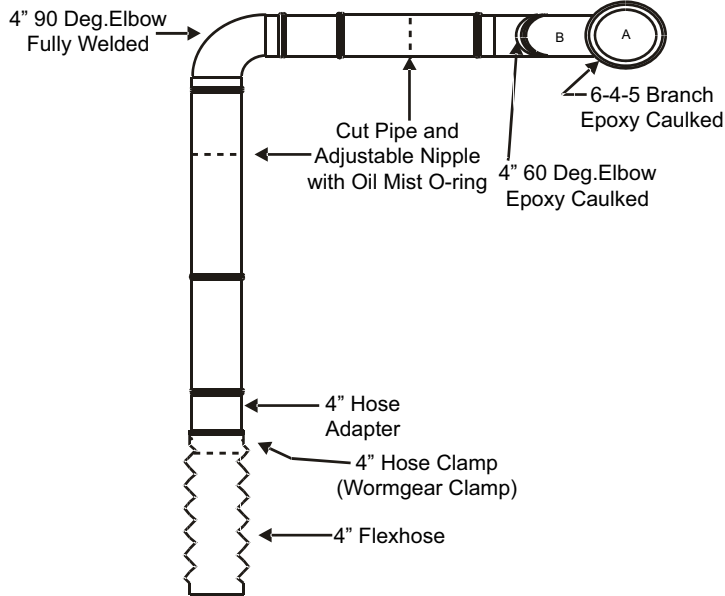

NOTE:
Blast gates are not commonly used for wet systems. Use butterfly valves for flow control.
***Use Q-F clamps & Leak-Free gasketing

PLAN VIEW

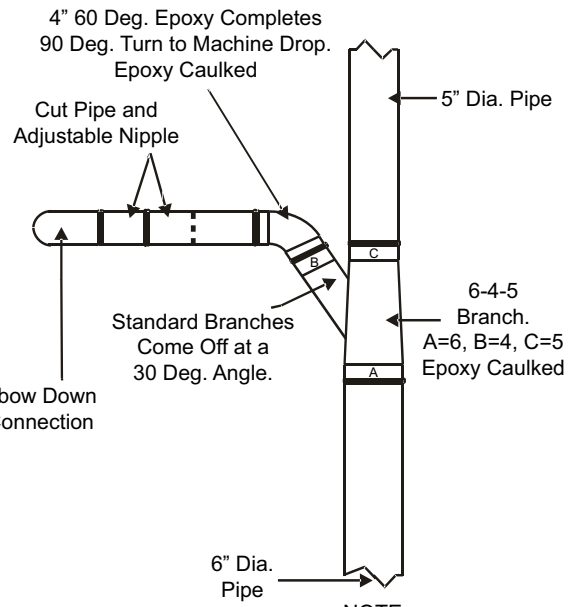

NOTE:
**Use Q-F clamps & Leak-Free gasketing

HARD DUCT TO MACHINE

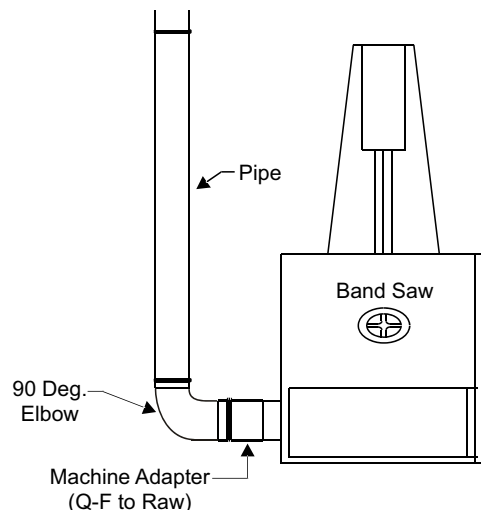



QUICK-FIT

THE WORLD'S FASTEST DUCTING

WALL FLASHING

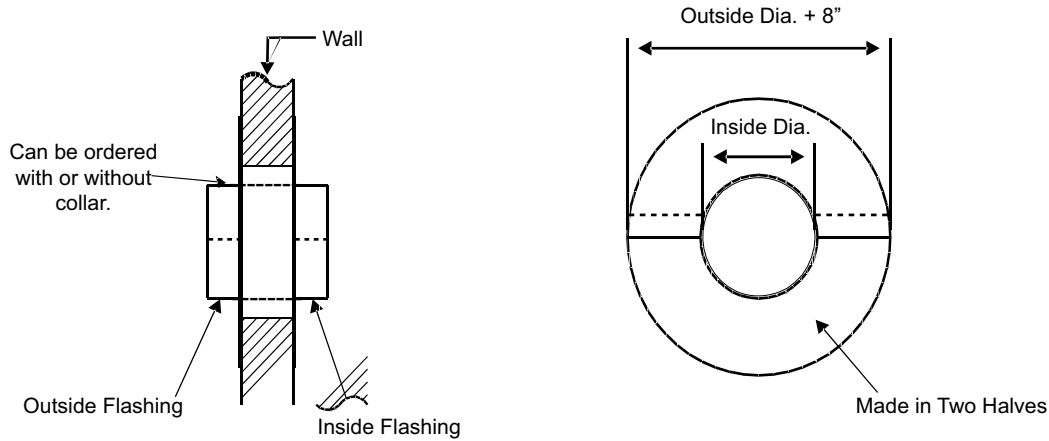

DESCRIPTION:

Provides weather protection for Wall penetration. Ordering one flashing provides you with both 1 inside and 1 outside flashing (4 halves).

AVAILABILITY:

Material: GALVANIZED or STAINLESS STEEL
 Sizes in inch: 4, 5, 6, 7, 8, 9, 10, 11, 12, 13, 14, 15, 16, 17, 18, 20, 22, 24, 26, 28, 30, 32, 34, 36, 38, 40

ROOF FLASHING & SKIRT (SOLD SEPARATELY)

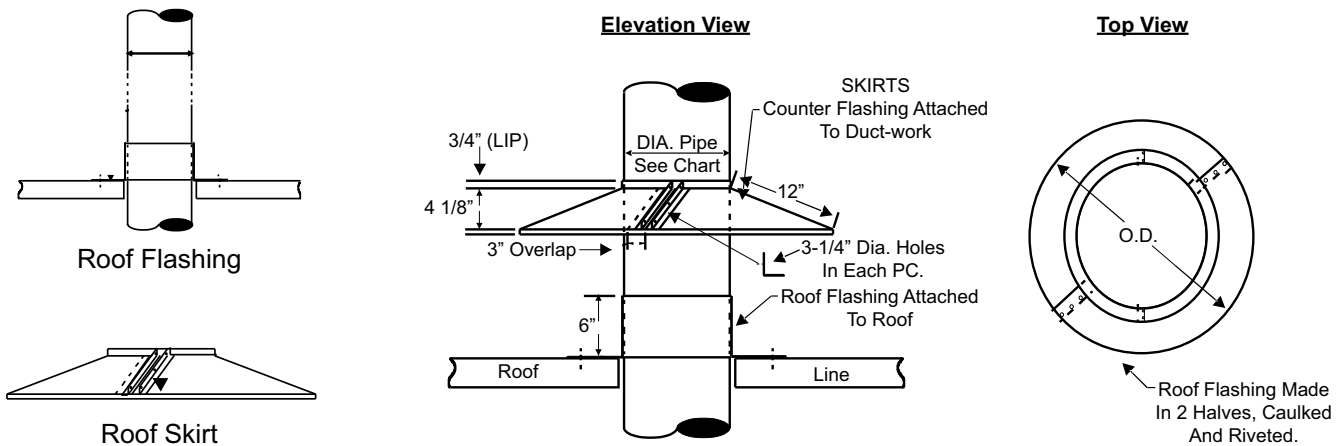

DESCRIPTION:

Provides weather protection for roof penetration.

AVAILABILITY:

Material: GALVANIZED or STAINLESS STEEL
 Sizes in inch: 4, 5, 6, 7, 8, 9, 10, 11, 12, 13, 14, 15, 16, 17, 18, 20, 22, 24, 26, 28, 30, 32, 34, 36, 38, 40

NOTE: Please specify Wall or Roof Flashing

| Quantity | Dia. Of Pipe | # of Sets |
|----------|--------------|-----------|
| | | |
| | | |
| | | |



QUICK-FIT

THE WORLD'S FASTEST DUCTING

ADJUSTABLE NIPPLE ASSEMBLY FOR DRY APPLICATION

INSTRUCTIONS FOR USING THE "QF" ADJUSTABLE NIPPLE WITH RUBBER O-RING FOR DRY SYSTEM

Each QF pipe section is 5 ft. in length. To accommodate an existing span, an adjustable nipple is used to shorten.



STEP 1

Measure distance to be spanned.

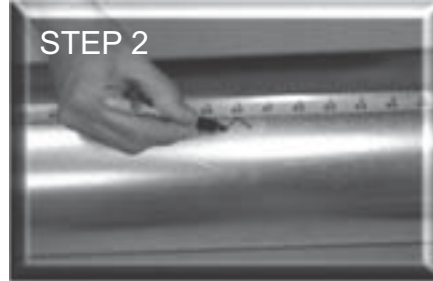

STEP 2

Mark distance to be spanned less 4".

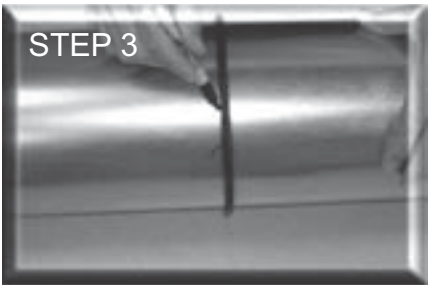

STEP 3

Use O-ring provided and mark for cut.



STEP 4

Drill access hole then cut with saw



STEP 5

Cut piece of pipe put O-ring on cut pipe, slide nipple over



STEP 6

Snap clamp over O-ring and one end of nipple.

FINISHED CONNECTION
USING THE ADJUSTABLE
NIPPLE ASSEMBLY.

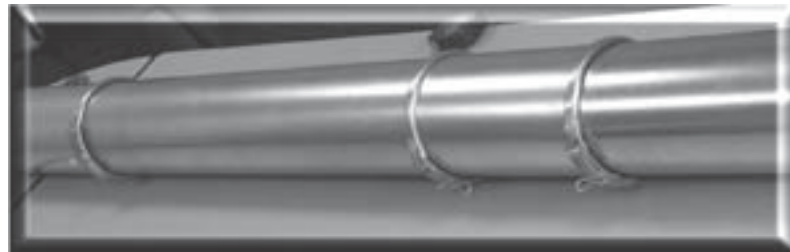

NOTE: KEEP CUT PIPE IN THE DIRECTION AS THE AIR FLOW.



QUICK-FIT

THE WORLD'S FASTEST DUCTING

NORDFAB'S LEAK-FREE GASKET AND O-RING

LEAK-FREE GASKET

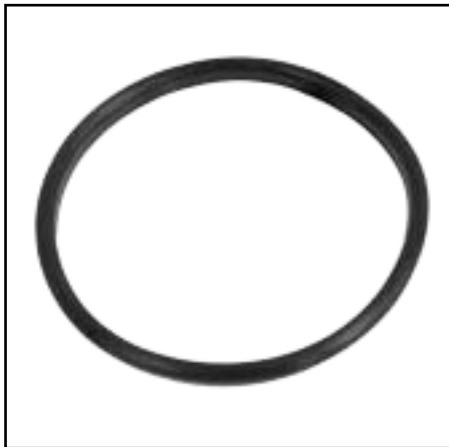

- General purpose oil resistant polymer
- Performs well with many oil, water and hydraulic fluid
- Good tear resistance
- Should not be used with solvents such as acetone, and MEK, ozone, chlorinated hydrocarbons and nitro hydrocarbons
- Fabricated with conductive material

Classification:

1. ASTM D-2000 M2BG510 A24 B34 EO14 EO34 EF11 EF21

Temperature Range:

Low Temperature Range: -30° F to +225° F
Intermittent: +280° F

LEAK-FREE O-RING

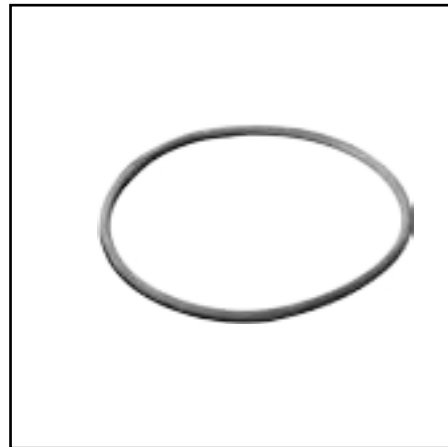

- Resists corrosion from weather
- Performs well with many oils and chemicals
- Resistant to wide temperature range
- Tough
- Can't damage by flexing and twisting
- Grey or black with grey mark

Classification:

1. ASTM D-1056-68.....SBE43
2. ASTM D-1056-85, 91, 98.....2B3

Temperature Range:

Low Temperature Range: -30° F to 225° F
Intermittent +280° F

NOTE: These materials work in conjunction with Nordfab's standard O-Ring. It does not replace it. See Installation Guidelines enclosed.

NORDFAB can't guarantee that these materials will work on every application. Please see above for manufacturer's classifications on these materials. When ordering for mist application specify epoxy caulk.



QUICK-FIT

THE WORLD'S FASTEST DUCTING

LEAK-FREE GASKET INSTALLATION

The molded Nitrile gaskets slip easily onto one end of the duct and are connected with a standard Q-F clamp to form a tight and re-useable seal. **Note the direction of the airflow when installing the duct.**



- 1) Wipe rolled edge with clean cloth. Then apply a high tack gasket adhesive per the manufacturer's instructions. High tack gasket adhesives can be purchased locally at industrial or automotive suppliers in either aerosol spray or brushable formulations.

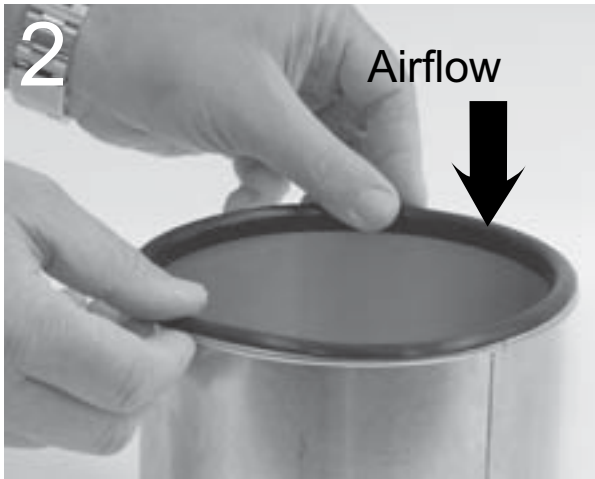

- 2) Carefully place the gasket along the rolled edge of the part, being careful to avoid kinks or voids. Only one gasket is needed per joint.



- 3) Join the gasketed end of the pipe to a non-gasketed end of the next part in the ducting run using a standard Q-F clamp. The oil-mist gasket, in addition to the gasket inside the Q-F clamp, provides dual protection against leakage.



QUICK-FIT

THE WORLD'S FASTEST DUCTING

INSTALLATION OF ADJUSTABLE NIPPLE FOR OIL MIST OR WET APPLICATIONS

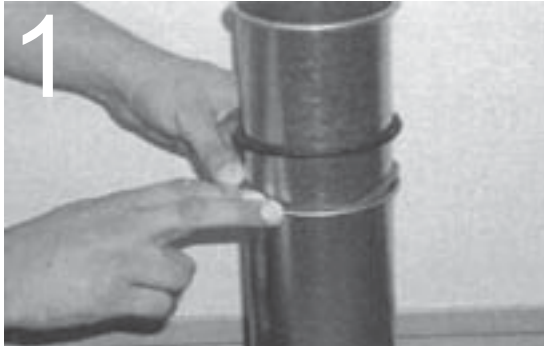

The patented Nordfab “adjustable nipple” provides unlimited flexibility in the length of a duct run.

1. Cut a standard piece of pipe to length and insert it into the short adjustable nipple section. This assembly will telescope to any length. Place the soft grey (or black with grey mark) o-ring seal onto the cut (inside) piece of pipe and seat it evenly against the rolled metal edge of the adjustable nipple.



2. Place the harder black o-ring seal against the outside of the inner grey seal.

The order should be as follows:

- a) rolled edge or nipple; against
- b) soft, small-diameter o-ring; against
- c) standard Nordfab o-ring

Airflow



3. Finally clamp the standard Q-F clamp over the rolled metal edge of the adjustable nipple and the hard rolled black o-ring for a leak-free connection. [Make sure both seals fit completely under the clamp and that the air-flows from the cut pipe towards the adjustable nipple].



QUICK-FIT

THE WORLD'S FASTEST DUCTING

SIZING A "Q-F" SYSTEM

NORDFAB offers assistance to those sales people and customers who have never designed a ducting system before. We can assist you in determining the correct duct size and configuration that will supply you with the correct flow.

We have the ability to assist customers in designing a blast-gated system; taking into account flow dynamics that will be affected by blast gates. While blast gates can be used to effectively utilize an undersized filtering system, they can also destroy the flow if not properly placed.

USING THE CFM / FPM CHART

Different materials need to be moved at different velocities to prevent the material from falling out of the air stream. For example: wood chips and saw dust flow well at 4500 feet per minute. Referring to the chart on the next page, you will see that a 4" duct will convey 395 CFM at 4500 FPM. This will mean that a 4" pick-up on a machine will take 395 CFM from your filtering system; or working in reverse, if you know that a machine will require approximately 400 CFM to remove the waste, then you should design a 4" duct for the purpose.

| Description of Conveyed Material | Velocity FPM | Example |
|----------------------------------|---------------|--|
| Gases | 1,000 - 2,000 | All Vapors, Gases and Smoke |
| Fumes | 2,000 - 2,500 | Welding |
| Oil Mist | 2,000 - 2,500 | Oily Vapor or Oily Smoke |
| Very Fine Light Dust | 2,500 - 3,000 | Cotton Lint, Litho Powder, Wood Flour |
| Dry Dusts and Powders | 3,500 - 4,000 | Light Shavings, Rubber Dust, Soap Dust |
| Typical Industrial Dust | 3,000 - 4,000 | Grinding or Buffing Dust, Granite/Brick/Clay Dust |
| Heavy Dusts | 4,000 - 4,500 | Heavy or Wet Sawdust, Metal Turnings, Sand Blast Dust, Wood Blocks |
| Heavy or Moist | 4,500 + | Moist Cement Dust, Quick-Lime Dust, Sticky Buffing Lint |

| AIR VOLUME IN DUCTS IN CUBIC FEET PER MINUTE (CFM) | | | | | | | | | | |
|---|-------------|-------------|-------------|-------------|-------------|-------------|-------------|-------------|-------------|-------------|
| VELOCITY IN FEET PER MINUTE (FPM) | | | | | | | | | | |
| DUCT Ø | 2000 | 2500 | 3000 | 3500 | 4000 | 4500 | 5000 | 5500 | 6000 | 7000 |
| 3 | 100 | 125 | 150 | 170 | 195 | 220 | 245 | 270 | 295 | 345 |
| 4 | 175 | 220 | 260 | 305 | 350 | 395 | 440 | 485 | 525 | 615 |
| 5 | 275 | 340 | 410 | 475 | 545 | 615 | 680 | 750 | 820 | 955 |
| 6 | 395 | 490 | 590 | 685 | 785 | 885 | 980 | 1080 | 1180 | 1375 |
| 7 | 535 | 670 | 800 | 935 | 1070 | 1205 | 1335 | 1470 | 1605 | 1870 |
| 8 | 700 | 875 | 1050 | 1220 | 1395 | 1570 | 1745 | 1920 | 2095 | 2445 |
| 9 | 885 | 1105 | 1325 | 1545 | 1765 | 1990 | 2210 | 2430 | 2650 | 3090 |
| 10 | 1090 | 1365 | 1635 | 1910 | 2180 | 2455 | 2725 | 3000 | 3270 | 3820 |
| 11 | 1320 | 1650 | 1980 | 2310 | 2640 | 2970 | 3300 | 3630 | 3960 | 4620 |
| 12 | 1570 | 1965 | 2355 | 2750 | 3140 | 3535 | 3925 | 4320 | 4710 | 5500 |
| 13 | 1850 | 2300 | 2770 | 3225 | 3685 | 4150 | 4610 | 5070 | 5530 | 6450 |
| 14 | 2140 | 2675 | 3205 | 3740 | 4275 | 4810 | 5345 | 5880 | 6415 | 7485 |
| 15 | 2450 | 3070 | 3680 | 4300 | 4900 | 5520 | 6130 | 6750 | 7360 | 8590 |
| 16 | 2790 | 3490 | 4190 | 4885 | 5585 | 6285 | 6980 | 7680 | 8380 | 9775 |
| 17 | 3150 | 3940 | 4730 | 5515 | 6300 | 7090 | 7880 | 8670 | 9450 | 11030 |
| 18 | 3535 | 4420 | 5300 | 6185 | 7070 | 7950 | 8835 | 9720 | 10600 | 12370 |
| 20 | 4365 | 5455 | 6545 | 7635 | 8725 | 9815 | 10910 | 12000 | 13090 | 15270 |
| 22 | 5280 | 6600 | 7920 | 9240 | 10560 | 11880 | 13200 | 14520 | 15840 | 18480 |
| 24 | 6285 | 7855 | 9425 | 10995 | 12656 | 14135 | 15710 | 17280 | 18850 | 21995 |
| 26 | 7370 | 9210 | 11055 | 12900 | 14740 | 16580 | 18420 | 20270 | 22110 | 25800 |
| 28 | 8550 | 10685 | 12820 | 14960 | 17100 | 19230 | 21310 | 23500 | 25650 | 29920 |
| 30 | 9800 | 12260 | 14700 | 17170 | 19625 | 22080 | 24530 | 26990 | 29440 | 34350 |
| 32 | 11160 | 13950 | 16750 | 19541 | 22330 | 25120 | 27910 | 30700 | 33490 | 39070 |
| 34 | 12600 | 15755 | 18905 | 22055 | 25210 | 28360 | 31510 | 34660 | 37810 | 44115 |
| 36 | 14130 | 17665 | 21195 | 24730 | 28260 | 31800 | 35325 | 38860 | 42390 | 49455 |
| 38 | 15745 | 19680 | 23615 | 27550 | 31490 | 35425 | 39360 | 43295 | 47230 | 55100 |
| 40 | 17445 | 21800 | 26170 | 30530 | 34890 | 39250 | 43610 | 47975 | 52330 | 61055 |

"QF" PARTS LIST TAKE-OFF WORKSHEET

Your Name: _____ Fax: _____ Page _____ of _____

Company Name: _____ Phone: _____ Project: _____ Date: _____

| QF DIA. | PIPE 5'0" LONG (3"Ø 39") | ADJ. NIPPLE INCL O-RING | ELBOWS | | | BLAST GATES | FLOOR SWEEP | MACHINE ADAPTOR STAND. IS QF TO ID | FLEX HOSE ADAPT. | QF CLAMP | PIPE HANGER | FLEX HOSE RUBBER OR STEEL | FLEX HOSE CLAMP | MISC. FITTINGS (REDUCERS, ADAPTORS, TRANSITIONS, ANY FITTINGS THAT CAN NOT BE SPECIFIED ELSEWHERE) | BRANCH, DOUBLE BRANCH & Y BRANCH | | | |
|---------|--------------------------|-------------------------|--------|-----|-----|-------------|-------------|------------------------------------|------------------|----------|-------------|---------------------------|-----------------|--|----------------------------------|---|---|---|
| | | | 90° | 60° | 45° | | | | | | | | | | 30° | A | B | C |
| 3" | | | | | | | | | | | | | | | | | | |
| 4" | | | | | | | | | | | | | | | | | | |
| 5" | | | | | | | | | | | | | | | | | | |
| 6" | | | | | | | | | | | | | | | | | | |
| 7" | | | | | | | | | | | | | | | | | | |
| 8" | | | | | | | | | | | | | | | | | | |
| 9" | | | | | | | | | | | | | | | | | | |
| 10" | | | | | | | | | | | | | | | | | | |
| 11" | | | | | | | | | | | | | | | | | | |
| 12" | | | | | | | | | | | | | | | | | | |
| 13" | | | | | | | | | | | | | | | | | | |
| 14" | | | | | | | | | | | | | | | | | | |
| 15" | | | | | | | | | | | | | | | | | | |
| 16" | | | | | | | | | | | | | | | | | | |
| 17" | | | | | | | | | | | | | | | | | | |
| 18" | | | | | | | | | | | | | | | | | | |
| 20" | | | | | | | | | | | | | | | | | | |
| 22" | | | | | | | | | | | | | | | | | | |
| 24" | | | | | | | | | | | | | | | | | | |

QUICK-FIT FAST FAX: 336-889-7873

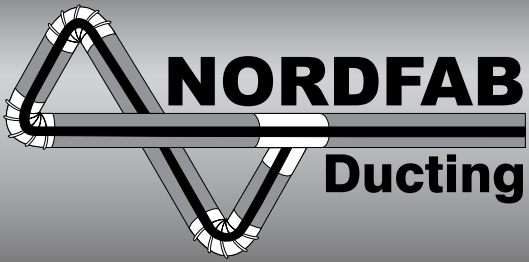

The world's [***FASTEST***] ducting



QUICK-FIT FAST FAX TO: 336-889-7873

HAVE MY LOCAL DUCTING EXPERT CONTACT ME

NAME: _____ COMPANY: _____

ADDRESS: _____ CITY: _____ ST: _____ ZIP: _____

DATE NEEDED: _____

PHONE: _____ FAX: _____ EMAIL: _____

CURRENT NEED: _____

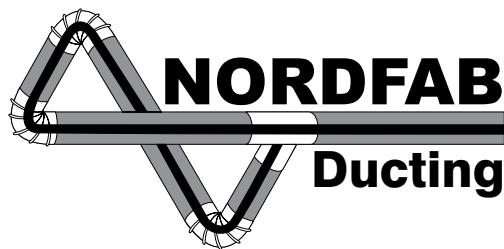

**150 Transit Ave/ PO Box 190
Thomasville, NC 27361-0190
Toll Free: 800-532-0830
Fax: 336-889-7873**

**1050 Spice Island Dr.
Sparks, NV 89431
Toll Free: 800-532-0830
Fax: 336-410-0872**

www.nordfab.com